

Instruction Manual



Genesis[®] 7537

Hydro-Pneumatic Power Tool

Contents

Safety Rules	4	Maintenance	
Specifications		Dismantling 07537-00200	24-25
Specification for 7537 Tool	5	General Assembly and Parts List 07537-00200	26-27
Tool Dimensions	5	Priming	
Intent of Use	6	Oil Details	28
Putting into Service		Hyspin® VG 32 and AWS 32 Oil Safety Data	28
Air Supply	7	Priming Kit	28
Mechanical Cursors	8	Priming Procedure	29
Cursor	9	Fault Diagnosis	
Loading and Reloading the Tool	10	Symptom, Possible Cause and Remedy	30
Operating Procedure	10		
Mandrel Follower Springs Identification and Orientation	11		
Nose Assemblies			
Nose Jaws	12		
Selecting a Nose Jaw	13		
Nose Jaw Selection - Imperial	14		
Nose Jaw Selection - Metric	15		
Mandrels and Mandrel Follower Springs	16		
Chobert® and Grovit® - Imperial	16		
Chobert® and Grovit® - Metric	17		
Briv® - Imperial	18		
Mandrel Head Types and 'P' Length	19		
Briv® - Metric	19		
Avlug®, Avsert®, Avtronic® and Rivscrew®			
Imperial and Metric	20		
Servicing the Tool			
Daily	21		
Weekly	21		
MolyLithium Grease EP 3735 Safety Data	21		
Molykote® 55m Safety Data	22		
Molykote® 111 Safety Data			
Service Kits	23		

LIMITED WARRANTY

Avdel makes the limited warranty that its products will be free of defects in workmanship and materials which occur under normal operating conditions. This Limited Warranty is contingent upon: (1) the product being installed, maintained and operated in accordance with product literature and instructions, and (2) confirmation by Avdel of such defect, upon inspection and testing. Avdel makes the foregoing limited warranty for a period of twelve (12) months following Avdel's delivery of the product to the direct purchaser from Avdel. In the event of any breach of the foregoing warranty, the sole remedy shall be to return the defective Goods for replacement or refund for the purchase price at Avdel's option. THE FOREGOING EXPRESS LIMITED WARRANTY AND REMEDY ARE EXCLUSIVE AND ARE IN LIEU OF ALL OTHER WARRANTIES AND REMEDIES. ANY IMPLIED WARRANTY AS TO QUALITY, FITNESS FOR PURPOSE, OR MERCHANTABILITY ARE HEREBY SPECIFICALLY DISCLAIMED AND EXCLUDED BY AVDEL.

Avdel UK Limited policy is one of continuous product development and improvement and we reserve the right to change the specification of any product without prior notice.

Safety Rules

This instruction manual must be read with particular attention to the following safety rules, by any person installing, operating, or servicing this tool.

- 1 Do not use outside the design intent.
- 2 Do not use equipment with this tool/machine other than that recommended and supplied by Avdel UK Limited.
- 3 Any modification undertaken by the customer to the tool/machine, nose assemblies, accessories or any equipment supplied by Avdel UK Limited. or their representatives, shall be the customer's entire responsibility. Avdel UK Limited. will be pleased to advise upon any proposed modification.
- 4 The tool/machine must be maintained in a safe working condition at all times and examined at regular intervals for damage and function by trained competent personnel. Any dismantling procedure shall be undertaken only by personnel trained in Avdel UK Limited procedures. Do not dismantle this tool/machine without prior reference to the maintenance instructions. Please contact Avdel UK Limited. with your training requirements.
- 5 The tool/machine shall at all times be operated in accordance with relevant Health and Safety legislation. In the U.K. the "Health and Safety at Work etc. Act 1974" applies. Any question regarding the correct operation of the tool/machine and operator safety should be directed to Avdel UK Limited.
- 6 The precautions to be observed when using this tool/machine must be explained by the customer to all operators.
- 7 Always disconnect the airline from the tool/machine inlet before attempting to adjust, fit or remove a nose assembly.
- 8 Do not operate a tool/machine that is directed towards any person(s) or the operator.
- 9 Always adopt a firm footing or a stable position before operating the tool/machine.
- 10 Ensure that vent holes do not become blocked or covered and that hoses are always in good condition.
- 11 The operating pressure shall not exceed 7 bar (100 lbf/in²).
- 12 The combination of fastener, mandrel, hole size and sheet thickness shall be in accordance with Avdel UK Limited. Specifications.
- 13 Do not operate the tool if it is not fitted with a complete nose assembly unless specifically instructed otherwise.
- 14 When using the tool, the wearing of safety glasses is required both by the operator and others in the vicinity to protect against fastener ejection, should a fastener be placed 'in air'. We recommend wearing gloves if there are sharp edges or corners on the application.
- 15 Take care to avoid entanglement of loose clothes, ties, long hair, cleaning rags etc. in the moving parts of the tool which should be kept dry and clean for best possible grip.
- 16 When carrying the tool from place to place keep hands away from the trigger/lever to avoid inadvertent startup.
- 17 Excessive contact with hydraulic oil should be avoided. To minimize the possibility of rashes, care should be taken to wash thoroughly.

I M P O R T A N T

While a small amount of wear and marking will naturally occur through normal and correct use of mandrels, they must be regularly examined for excessive wear and marking, with particular attention to the head diameter, the tail jaw gripping area of the shank or heavy pitting of the shank and any mandrel distortion. Mandrels which fail during use could forcibly exit the tool. It is the customer's responsibility to ensure that mandrels are replaced before any excessive levels of wear and always before the maximum recommended number of placings. Contact your Avdel. representative who will let you know what that figure is by measuring the broach load of your application with a calibrated test tool. These tools can also be purchased under Part Number 07900-09080, supplied with all necessary information for testing in this manual.

Specifications

Specification for 07537 Tool

Air Pressure	Minimum - Maximum	5-7 bar (70-100 lbf/in ²)
Free Air Volume Required	@ 5.1 bar /75 lbf/in ²	2.6 litres (0.09 ft ³)
Stroke	Minimum	28.0 mm (1.10 in)
Pull Force	@ 5.5 bar /80 lbf/in ²	3.89 kN (875 lbf)
Cycle time	Approximately	1 second
Noise Level	Less than	70 dB(A)
Weight	Tool	2.3 kg (5.06 lb)
Vibration	Less than	2.5 m/s ² (8 ft/s ²)

Tool Dimensions

Part Number 07537-00200

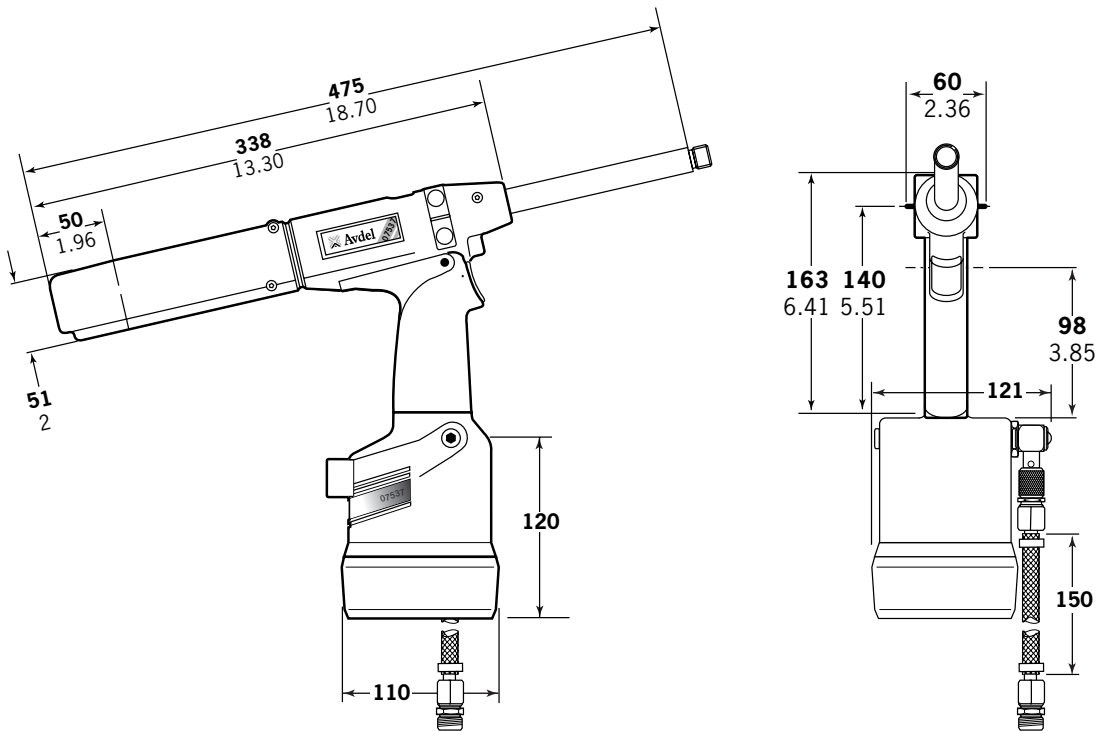

Intent of Use

The pneumatic 07537 tool is a handheld lightweight tool designed to place Avdel® speed fasteners (except 1/16" Avlug®) making it ideal for batch or flow-line assembly in a wide variety of applications throughout all industries.

Part numbers are shown to order a complete tool but no nose equipment.

The tool part number for the 07537 model is 07537-00200. See the general assemblies on pages 26-27.

The tool will place most repetition fasteners, as shown in the table below.

The tool is used with specific nose equipment. Reference must be made to the Nose Equipment section of the manual when selecting compatible components for the type and size of fastener used in your application (see pages 12-20). Nose jaw dimensions are shown on page 13.

FASTENER NAME	FASTENER SIZE											
	3/32"	1/8"	5/32"	3/16"	1/4"	2.5mm 2.8mm	3mm	3.5mm	4mm	6mm	M2.5 4-40 UNC	M3 6-32 UNC
CHOBERT®	●	●	●	●	●							
GROVIT®	●	●	●	●								
AVLUG®	●	●										
BRIV®	●	●	●	●						●		
RIVSCREW®						●	●	●	●			
AVTRONIC®						●						
AVSERT®											●	●

Putting into Service

Air Supply

All tools are operated with compressed air at an optimum pressure of 5.5 bar. We recommend the use of pressure regulators and filtering systems on the main air supply. These should be fitted within 3 metres of the tool (see diagram below) to ensure maximum tool life and minimum tool maintenance.

Air supply hoses should have a minimum working effective pressure rating of 150% of the maximum pressure produced in the system or 10 bar, whichever is the highest. Air hoses should be oil resistant, have an abrasion resistant exterior and should be armoured where operating conditions may result in hoses being damaged. All air hoses MUST have a minimum bore diameter of 6.4 millimetres or 1/4 inch.

Read servicing daily details page 21.

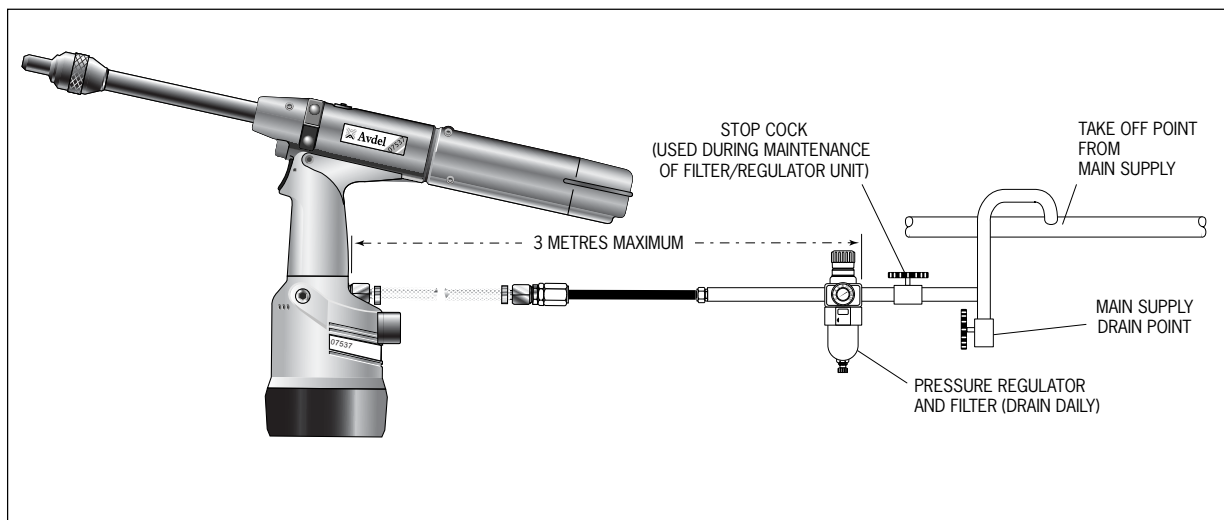

Putting into Service

Mechanical Cursors

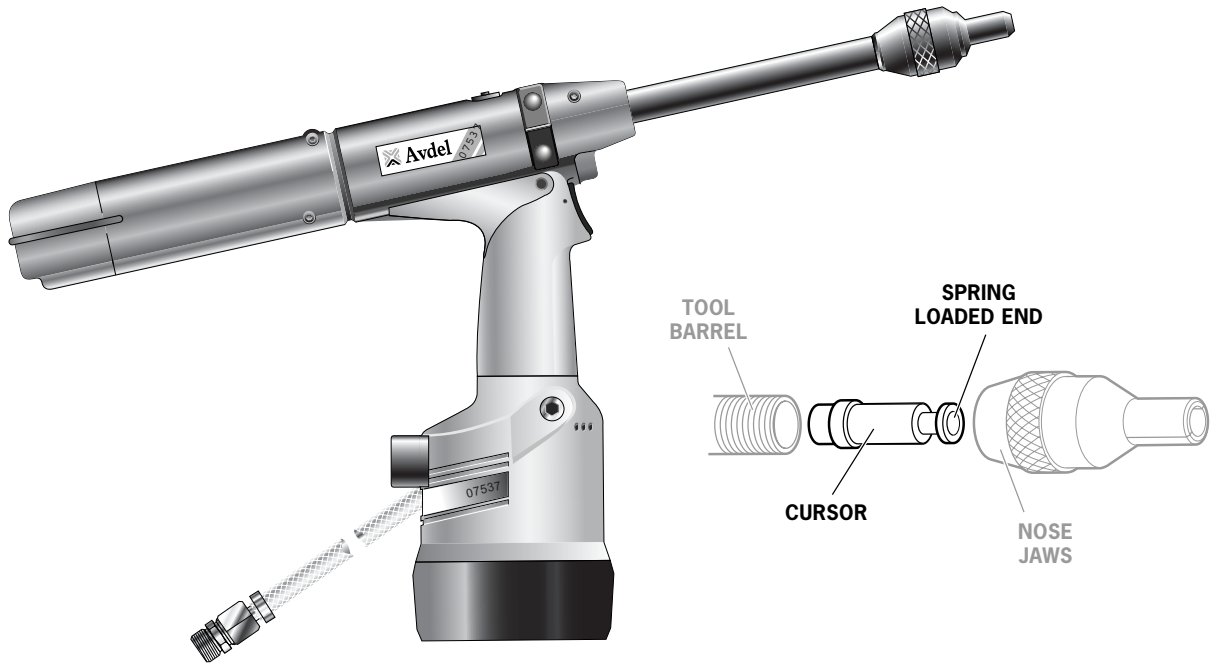

For reference there are three different mechanical cursor types:

- 07271-01100 Used for Standard mandrels and 5/32" Disposable mandrels
- 07279-05843 Used for 1/8" Disposable mandrels
- 07279-05845 Used for 3/16" Disposable mandrels

The difference in the above assemblies is the internal diameter of the End Plug.

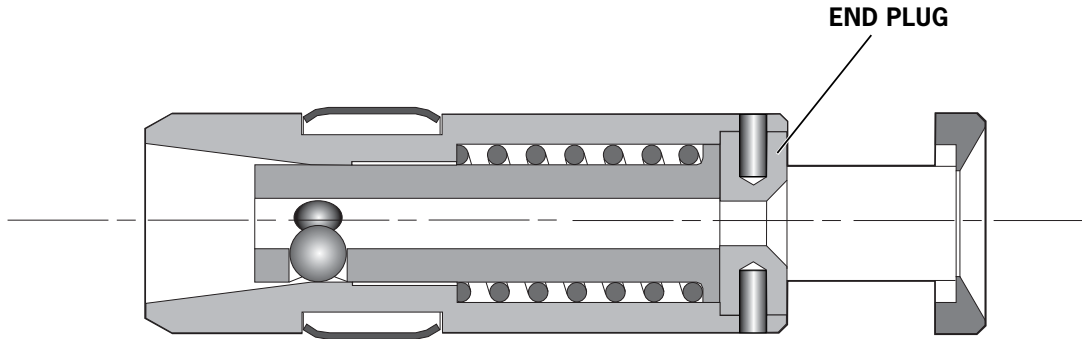

These are colour coded see below:

MECHANICAL CURSOR PART NO.	END PLUG PART NO.	COLOUR	HOLE DIAMETER (mm)
07271-01100	07150-00402	PLAIN STEEL	2.7
07279-05843	07159-05844	GOLD	2.2
07279-05845	07159-05846	SILVER	3.3

Cursor

IMPORTANT

If fitted incorrectly, the cursor will not allow feeding of the fasteners.

While the cursor will be fitted the correct way round when the tool is supplied, we recommend that you check its orientation before fitting the nose equipment. The sprung loaded, slightly concave, end of the cursor should point towards the front of the tool as shown in the illustration.

When fitted the correct way round, the cursor will easily slide out of the barrel when a mandrel is pushed into its centre then pulled back.

To reverse the orientation of the cursor, follow these steps:

Item numbers in **bold** refer to the general assembly and parts list for the 07537-00200 on pages 26-27.

- Remove the clip **48** and slide off end cap **50**.
- Using an Allen Key, remove one cap head screw **5** ensuring that any trapped air is exhausted. remove the second cap head screw **5**.
- Pull out rear plug **47**.
- Pull out tail jaw piston assembly **51** together with jaws **34**.
- Lift out spring **35** and jaw housing **41**.
- Insert a mandrel into the hole in the rear end of barrel **44** until it protrudes through the front of the barrel, then pull out the mandrel and cursor together through the front.
- Reassemble components in reverse order.
- Insert Mechanical Cursor Assembly **36** into the front of the barrel, correct way round.

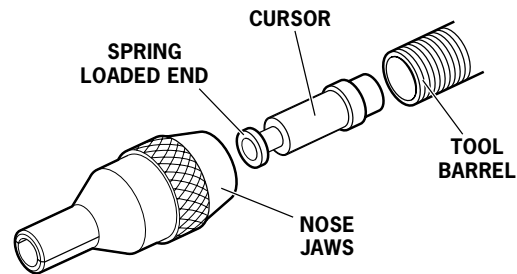

Loading and Reloading the Tool

IMPORTANT

The procedure for loading the tool and for fitting the nose equipment to the tool is integral.

When ordering a complete tool or system you will normally be supplied with all the nose equipment required for the fastener to be placed. To identify nose equipment components or to select the correct elements, read the nose equipment section, on pages 12-20.

If you have been supplied with a nose jaw, mandrels and mandrel follower springs proceed with loading the tool and fitting the nose equipment as shown overleaf.

Item numbers in **bold** refer to the general assembly and parts list for the 07537-00200 on pages 26-27.

Putting into Service

Loading the Tool

- Connect the air supply to the tool.
- Open tail jaws **34** which grip the mandrel, by switching off the tail jaw switch (items **22** and **23**).
- Screw selected nose jaws onto barrel **44** of the tool.
- * Insert a mandrel into the tail end of the fasteners through the paper pod.
- Slide the mandrel follower spring onto the mandrel ensuring correct orientation, as shown in the table on page 11.
- Gripping the tail end of the mandrel, tear off the paper pod from around the fasteners.
- Open the nose jaws either by rotating the outer ring on Cam operated jaws or by pushing outwards on the jaw ends, as illustrated below left.
- Insert the previously assembled mandrel, mandrel follower spring and fasteners into the nose jaws until the first fastener to be placed is protruding from the nose jaw.
- Close the nose jaws and adjust so that the first fastener protrudes by 1.5mm - 3mm ($1/16''$ to $1/8''$), as shown in the illustration below right.
- Close the tail jaws to ensure the mandrel is gripped, by switching on the tail jaw switch (items **22** and **23**).

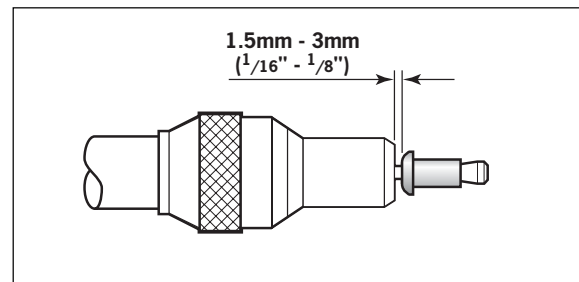
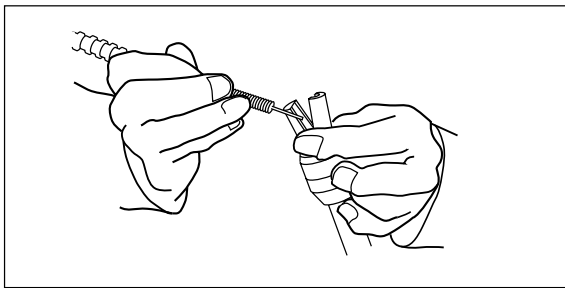

Reloading the Tool

- Open tail jaws **34** of tool.
- Open the nose jaws and pull the empty mandrel and mandrel follower spring out of the tool.
- Reload the tool by following the above instructions, starting at stage •*.

Operating Procedure

IMPORTANT

You must check that the cursor orientation and the nose equipment are correct before attempting to operate the tool.

- Push the fastener, protruding from the nose jaws, fully into the application holes ensuring that the tool is held square.
- Operate the trigger without releasing - the mandrel head is pulled through the fastener, forming the fastener into the application.
- Remove the tool.
- Release the trigger. The next fastener will be automatically presented through the nose jaws, ready for placing.

Item numbers in **bold** refer to the general assembly and parts list for the 07537-00200 on pages 26-27.

Putting into Service

MANDREL FOLLOWER SPRINGS IDENTIFICATION AND ORIENTATION				
FASTENER		NOSE JAW (SEE NOSE EQUIPMENT SECTION)	MANDREL SIZE	MANDREL/MANDREL FOLLOWER SPRING AND FASTENER ASSEMBLY
NAME	SIZE			
BRIV®	3/32"	STANDARD TAPERED	ALL	
	3/32"	LIMITED ACCESS & LIMITED ACCESS CAM OPERATED	ALL	
	1/8"	ALL	ALL	
	5/32"	ALL	ALL	
	3/16"	ALL	ALL	
	6mm	STANDARD	ALL EXCEPT 3rd OVERSIZE	
CHOBERT® AVLUG® GROVIT®	3/32"	ALL EXCEPT STANDARD TAPERED, LIMITED ACCESS	ALL	
	3/32"	STANDARD TAPERED, LIMITED ACCESS	ALL	
	1/8"	ALL	ALL	
CHOBERT® GROVIT®	5/32"	ALL	ALL EXCEPT 3rd OVERSIZE	
	5/32"	ALL	3rd OVERSIZE	
	3/16"	ALL	ALL EXCEPT 2nd OVERSIZE	
	3/16"	ALL	2nd OVERSIZE	
CHOBERT®	1/4"	ALL	ALL	
RIVSCREW®	2.8mm	ALL	ALL	
	3mm	ALL	ALL	
	3.5mm	ALL	ALL	
	4mm	ALL	ALL	
AVSERT®	2.5mm	ALL	ALL	
	4 x 40 UNC	ALL	ALL	
	3mm	ALL	ALL	
AVTRONIC®	2.5mm	ALL	ALL	
	2.8mm	ALL EXCEPT LIMITED ACCESS	ALL	
	2.8mm	LIMITED ACCESS	ALL	

Nose Assemblies

On speed fastening tools such as 0753 MkII type, the nose equipment always consists of three elements: a nose jaw, a mandrel and a mandrel follower spring. All three items are matched to the fastener being placed and to the hole size in the application.

IMPORTANT

To avoid complete dismantling of the tool it is essential to check the orientation of the cursor before fitting the nose equipment to the tool. See 'CURSOR' section on page 9.

It is essential that the correct nose equipment is fitted to the tool to ensure both effective placing of the fastener and SAFE operation of the tool. READ THE SAFETY INSTRUCTIONS page 4 carefully.

To identify the correct combination of nose equipment to fit your tool first select a nose jaw by reading the section below then read the mandrel section to select part numbers both for the mandrel itself and for the mandrel follower spring. Mandrels and mandrel follower springs are illustrated on page 11.

To fit the nose equipment, follow the 'Loading the Tool' procedure page 10.

Nose Jaws

IMPORTANT

The wrong nose jaw could result in an incorrectly placed fastener or incorrect clench.

Nose Jaws can be categorised into 7 different basic shapes as illustrated opposite, even though internal dimensions will vary according to the fastener it is intended for. Exact dimensions referring to the letters in the illustrations opposite are indicated in the 'Nose Jaw Selection Tables' on pages 14-15.

For a particular shape, there may be several options of end form giving access benefits or fastener placing enhancement.

Flat

- Normal end form of all nose jaws.
- Suitable on all applications with no access restrictions.

Universal

- Designed for use with universal head Chobert® fasteners.
- Can also be used with Briv® fasteners to obtain the highest possible clench. Note this reduces the maximum grip range of the Briv® fastener by approximately 0.015" (0.4mm).

Recessed

- For use with Briv® fasteners ONLY.
- It gives a higher clench than a flat end form but less than a universal end form, with no reduction of the grip range of the fastener.

Tapered

- Available as shown in the 'Nose Jaw Selection Tables'.
- Allows greater accessibility than a flat end form and places the same range.

Head Forming

- For use with Rivscrew® fasteners ONLY.
- Deforms the head of the fastener to achieve good clench.

Nose Assemblies

Selecting a Nose Jaw

- List the name, size and material of the fastener to be placed.
- Look for this fastener in the first column of the nose jaw selection tables on page 14 if you use imperial measurements and on page 15 if you use metric units.
- Looking right across the table, take note of which nose jaws are available. ONLY those shown are available.
- Select which is most suitable for your application by referring to the respective nose jaw drawing. If your application has no access restriction, you should select the standard shape with a flat end form with or without a cam.

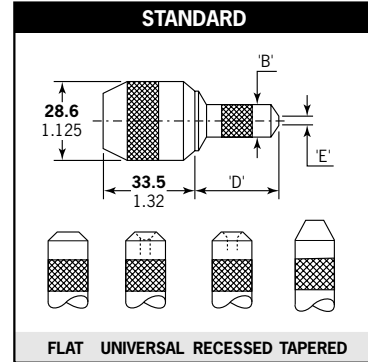

Available in 4 different end forms to place all fasteners (except Rivscrew). Suitable on applications with no or little access restriction.

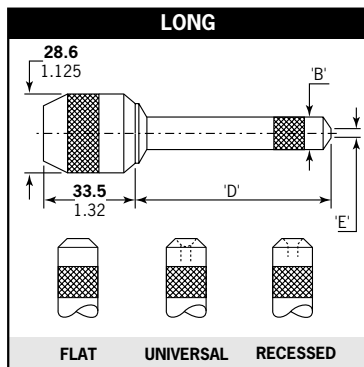

Available to place most of the fasteners. Allows more penetration into applications with no other access restriction.

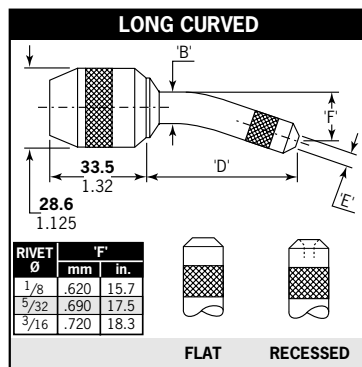

Available as shown in NOSE JAW SELECTION TABLE. Allows more penetration into applications with restricted access. Mandrels must be curved by hand to follow the shape of the jaw.

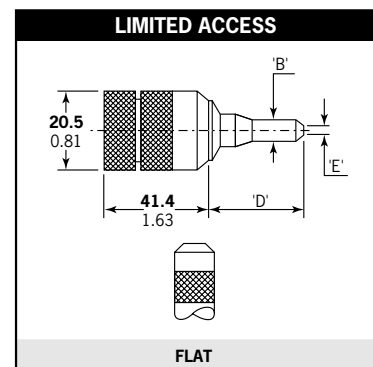

Available as shown in NOSE JAW SELECTION TABLE. Allows access into very restrictive applications.

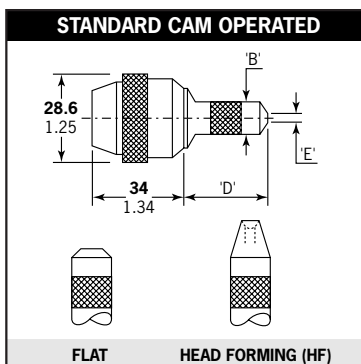

Available as shown in NOSE JAW SELECTION TABLE overleaf. Equivalent functions to the Standard and Limited Access above with the addition of a cam to ease and speed up the nose jaw opening thus the pod reloading procedure.

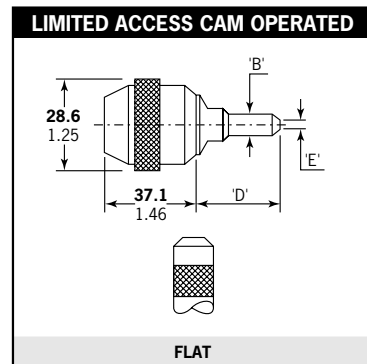
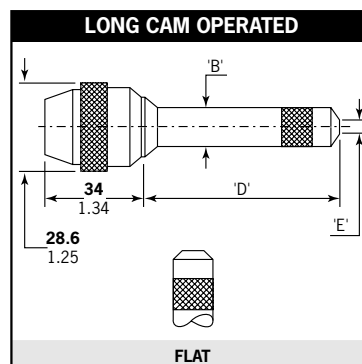

Dimensions shown in **bold** are millimetres. Other dimensions are in inches.

Nose Assemblies

Nose Jaw Selection - Imperial

The 'REF N°' column cross references with the 'REF N°' columns in the mandrel section. It identifies both the mandrel and mandrel follower spring required for a particular nose jaw with a specific fastener.

FASTENER	REF. N°	NOSE JAW					REF. N°	NOSE JAW				
		TYPE AND END FORM	PART N°	DIMENSIONS				TYPE AND END FORM	PART N°	DIMENSIONS		
				'B'	'D'	'E'				'B'	'D'	'E'
3/32" CHOBERT® & GROVIT®	1	STANDARD - FLAT	07150-03003	.36	1.30	.16	1	# STANDARD - UNIVERSAL	07150-03203	.36	1.33	.24
	1	STD. CAM OPERATED - FLAT	07170-04500	.36	1.30	.16	1	LTD. ACCESS CAM OPERATED	07177-03003	.20	1.18	.16
	2	STANDARD - TAPERED	07170-03103	.36	1.30	.16	3	LIMITED ACCESS	07274-01000	.22	1.07	.16
	4	LONG - FLAT	07150-04003	.41	2.30	.16	4	LONG CURVED - FLAT	07150-05003	.41	2.28	.16
1/8" CHOBERT® & GROVIT®	5	STANDARD - FLAT	07150-03004	.41	1.18	.20	5	# STANDARD - UNIVERSAL	07150-03204	.41	1.22	.32
	5	STANDARD - TAPERED	07170-03104	.41	1.19	.20	5	STD. CAM OPERATED - FLAT	07170-04600	.41	1.18	.20
	6	LONG - FLAT	07150-04004	.41	2.18	.20	6	# LONG - UNIVERSAL	07150-04204	.41	2.22	.30
	6	LONG CURVED - FLAT	07150-05004	.41	2.12	.20	6	LONG CAM OPERATED - FLAT	07170-05000	.41	2.18	.20
5/32" CHOBERT® & GROVIT®	7	STANDARD - FLAT	07150-03005	.48	1.30	.24	7	# STANDARD - UNIVERSAL	07150-03205	.48	1.35	.41
	7	STANDARD - TAPERED	07150-03105	.44	1.30	.24	7	STD. CAM OPERATED - FLAT	07170-04700	.48	1.30	.24
	8	LONG - FLAT	07150-04005	.48	2.30	.24	8	# LONG - UNIVERSAL	07150-04205	.48	2.35	.42
	8	LONG CURVED - FLAT	07150-05005	.48	2.23	.24	8	LONG CAM OPERATED - FLAT	07170-05100	.48	2.30	.24
3/16" CHOBERT® & GROVIT®	9	STANDARD - FLAT	07150-03006	.56	1.18	.33	9	# STANDARD - UNIVERSAL	07150-03206	.56	1.24	.47
	9	STANDARD - TAPERED	07150-03106	.56	1.18	.33	9	STD. CAM OPERATED - FLAT	07170-04800	.56	1.18	.33
	10	LONG - FLAT	07150-04006	.56	2.30	.33	10	# LONG - UNIVERSAL	07150-04206	.56	2.39	.48
	10	LONG CURVED - FLAT	07150-05006	.56	2.21	.33	10	LONG CAM OPERATED - FLAT	07170-05200	.56	2.30	.33
1/4" CHOBERT®	11	STANDARD - FLAT	07150-03008	.64	1.18	.39	11	STD. CAM OPERATED - FLAT	07170-04900	.64	1.18	.39
	12	LONG - FLAT	07150-04008	.64	2.18	.39	12	LONG CAM OPERATED - FLAT	07170-05300	.64	2.18	.39
3/32" BRIV® Brass only	13	STANDARD - TAPERED	07170-03103	.36	1.30	.15	14	LTD. ACCESS CAM OPERATED	07177-03003	.20	1.18	.16
	14	LIMITED ACCESS	07274-01000	.22	1.07	.16	-	-	-	-	-	-
1/8" BRIV® Al. Alloy, Brass, Steel	15	STANDARD - FLAT	07150-03004	.41	1.18	.20	15	STANDARD - RECESSED	07170-03004	.41	1.20	.30
	15	STANDARD - TAPERED	07170-03104	.41	1.19	.20	16	LONG - FLAT	07150-04004	.41	2.18	.20
	16	LONG - RECESSED	07170-03204	.41	2.18	.30	16	LONG CURVED - FLAT	07150-05004	.41	2.12	.20
	16	LONG CURVED - RECESSED	07170-03304	.41	2.12	.30	-	-	-	-	-	-
5/32" BRIV® Al. Alloy, Brass, Steel	17	STANDARD - FLAT	07150-03005	.48	1.30	.24	17	STANDARD - RECESSED	07170-03005	.48	1.32	.41
	18	LONG - FLAT	07150-04005	.48	2.30	.24	18	LONG - RECESSED	07170-03205	.48	2.30	.41
	18	LONG CURVED - FLAT	07150-05005	.48	2.23	.24	18	LONG CURVED - RECESSED	07170-03305	.48	2.23	.41
5/32" BRIV® St. Steel only	19	STANDARD - FLAT	07150-03005	.48	1.30	.24	19	STANDARD - RECESSED	07170-03005	.48	1.32	.41
	20	LONG - FLAT	07150-04005	.48	2.30	.24	20	LONG - RECESSED	07170-03205	.48	2.30	.41
	20	LONG CURVED - FLAT	07150-05005	.48	2.23	.24	20	LONG CURVED - RECESSED	07170-03305	.48	2.23	.41
3/16" BRIV® Al. Alloy, Brass, Steel	21	STANDARD - FLAT	07150-03006	.56	1.18	.33	21	STANDARD - RECESSED	07170-03006	.56	1.20	.47
	22	LONG - FLAT	07150-04006	.56	2.30	.33	22	LONG - RECESSED	07170-03206	.56	2.30	.47
	22	LONG CURVED - FLAT	07150-05006	.56	2.21	.33	22	LONG CURVED - RECESSED	07170-03306	.56	2.21	.47
3/16" BRIV® St. Steel only	23	STANDARD - FLAT	07150-03006	.56	1.18	.33	23	STANDARD - RECESSED	07170-03006	.56	1.20	.47
	24	LONG - FLAT	07150-04006	.56	2.30	.33	24	LONG - RECESSED	07170-03206	.56	2.30	.47
	24	LONG CURVED - FLAT	07150-05006	.56	2.21	.33	24	LONG CURVED - RECESSED	07170-03306	.56	2.21	.47
6mm BRIV® Al. Alloy, Steel	25	STD. CAM OPERATED	07170-05600	.64	1.21	.52	25	STANDARD - FLAT	07170-05800	.64	1.21	.52
	26	LONG CAM OPERATED	07170-05700	.64	2.19	.52	26	LONG - FLAT	07170-05900	.64	2.19	.52
3/32" AVLUG®	27	STANDARD - FLAT	07150-03003	.36	1.30	.16	27	STANDARD - TAPERED	07150-03103	.36	1.30	.16
	27	STD. CAM OPERATED - FLAT	07170-04500	.36	1.30	.16	28	LONG - FLAT	07150-04003	.41	2.30	.16
	28	LONG CURVED - FLAT	07150-05003	.41	2.28	.16	-	-	-	-	-	-
1/8" AVLUG®	29	STANDARD - FLAT	07150-03004	.41	1.18	.20	29	STANDARD - TAPERED	07170-03104	.41	1.19	.20
	29	STD. CAM OPERATED - FLAT	07170-04600	.41	1.18	.20	30	LONG - FLAT	07150-04004	.41	2.18	.20
	30	LONG CURVED - FLAT	07150-05004	.41	2.12	.20	30	LONG CAM OPERATED - FLAT	07170-05000	.41	2.18	.20
2.5mm 4-40 UNC AVSERT®	31	STANDARD - FLAT	07150-03003	.36	1.30	.16	-	-	-	-	-	-
3.0mm 6-32 UNC AVSERT®	32	STANDARD - FLAT	07150-03004	.41	1.18	.20	32	STD. CAM OPERATED - FLAT	07170-04600	.41	1.18	.20
2.5mm AVTRONIC®	33	STANDARD - FLAT	07150-03003	.36	1.30	.16	33	LTD. ACCESS CAM OPERATED	07271-08000	.41	1.18	.16
	34	LONG - FLAT	07150-04003	.41	2.30	.16	-	-	-	-	-	-
2.8mm AVTRONIC®	35	STANDARD - FLAT	07271-05600	.36	1.30	.16	36	LTD. ACCESS CAM OPERATED	07271-08100	.40	1.18	.16
	37	LONG - FLAT	07271-05900	.41	2.30	.16	-	-	-	-	-	-
2.8mm RIVSCREW®	38	STD. CAM OPERATED - HF	07271-03000	.41	1.18	.24	-	-	-	-	-	-
3.0mm RIVSCREW®	39	STD. CAM OPERATED - HF	07271-03000	.41	1.18	.24	-	-	-	-	-	-
3.5mm RIVSCREW®	40	STD. CAM OPERATED - HF	07271-03500	.41	1.18	.24	-	-	-	-	-	-
4.0mm RIVSCREW®	41	STD. CAM OPERATED - HF	07271-04000	.41	1.18	.25	-	-	-	-	-	-

These nose jaws are suitable for placing Chobert® rivets with a Universal Head Form. When used on the equivalent size of Briv®, the highest possible clench is achieved. Note when using Briv® fasteners, the maximum grip is reduced by approximately 0.015" (0.4mm).

Nose Assemblies

Nose Jaw Selection - Metric

FASTENER	REF. N°	NOSE JAW					REF. N°	NOSE JAW				
		TYPE AND END FORM	PART N°	DIMENSIONS				TYPE AND END FORM	PART N°	DIMENSIONS		
				'B'	'D'	'E'				'B'	'D'	'E'
3/32" CHOBERT® & GROVIT®	1	STANDARD - FLAT	07150-03003	9.14	33.02	4.06	1	# STANDARD - UNIVERSAL	07150-03203	9.14	33.78	6.10
	1	STD. CAM OPERATED - FLAT	07170-04500	9.14	33.02	4.06	1	LTD. ACCESS CAM OPERATED	07177-03003	5.08	29.97	4.06
	2	STANDARD - TAPERED	07170-03103	9.14	33.02	4.06	3	LIMITED ACCESS	07274-01000	5.59	27.18	4.06
	4	LONG - FLAT	07150-04003	10.41	58.42	4.06	4	LONG CURVED - FLAT	07150-05003	10.41	57.91	4.06
1/8" CHOBERT® & GROVIT®	5	STANDARD - FLAT	07150-03004	10.41	29.97	5.08	5	# STANDARD - UNIVERSAL	07150-03204	10.41	30.99	8.13
	5	STANDARD - TAPERED	07170-03104	10.41	30.23	5.08	5	STD. CAM OPERATED - FLAT	07170-04600	10.41	29.97	5.08
	6	LONG - FLAT	07150-04004	10.41	55.37	5.08	6	# LONG - UNIVERSAL	07150-04204	10.41	56.39	7.62
	6	LONG CURVED - FLAT	07150-05004	10.41	53.85	5.08	6	LONG CAM OPERATED - FLAT	07170-05000	10.41	55.37	5.08
5/32" CHOBERT® & GROVIT®	7	STANDARD - FLAT	07150-03005	12.19	33.02	6.10	7	# STANDARD - UNIVERSAL	07150-03205	12.19	34.29	10.41
	7	STANDARD - TAPERED	07150-03105	11.18	33.02	6.10	7	STD. CAM OPERATED - FLAT	07170-04700	12.19	33.02	6.10
	8	LONG - FLAT	07150-04005	12.19	58.42	6.10	8	# LONG - UNIVERSAL	07150-04205	12.19	59.69	10.67
	8	LONG CURVED - FLAT	07150-05005	12.19	56.64	6.10	8	LONG CAM OPERATED - FLAT	07170-05100	12.19	58.42	6.10
3/16" CHOBERT® & GROVIT®	9	STANDARD - FLAT	07150-03006	14.22	29.97	8.38	9	# STANDARD - UNIVERSAL	07150-03206	14.22	31.50	11.94
	9	STANDARD - TAPERED	07150-03106	14.22	29.97	8.38	9	STD. CAM OPERATED - FLAT	07170-04800	14.22	29.97	8.38
	10	LONG - FLAT	07150-04006	14.22	58.42	8.38	10	# LONG - UNIVERSAL	07150-04206	14.22	60.71	12.19
	10	LONG CURVED - FLAT	07150-05006	14.22	56.13	8.38	10	LONG CAM OPERATED - FLAT	07170-05200	14.22	58.42	8.38
1/4" CHOBERT®	11	STANDARD - FLAT	07150-03008	16.26	29.97	9.91	11	STD. CAM OPERATED - FLAT	07170-04900	16.26	29.97	9.91
	12	LONG - FLAT	07150-04008	16.26	55.37	9.91	12	LONG CAM OPERATED - FLAT	07170-05300	16.26	55.37	9.91
3/32" BRIV® Brass only	13	STANDARD - TAPERED	07170-03103	9.14	33.02	3.81	14	LTD. ACCESS CAM OPERATED	07177-03003	5.08	29.97	4.06
	14	LIMITED ACCESS	07274-01000	5.59	27.18	4.06	-	-	-	-	-	-
1/8" BRIV® Al. Alloy, Brass, Steel	15	STANDARD - FLAT	07150-03004	10.41	29.97	5.08	15	STANDARD - RECESSED	07170-03004	10.41	30.48	7.62
	15	STANDARD - TAPERED	07170-03104	10.41	30.23	5.08	16	LONG - FLAT	07150-04004	10.41	55.37	5.08
	16	LONG - RECESSED	07170-03204	10.41	55.37	7.62	16	LONG CURVED - FLAT	07150-05004	10.41	53.85	5.08
	16	LONG CURVED - RECESSED	07170-03304	10.41	53.85	7.62	-	-	-	-	-	-
5/32" BRIV® Al. Alloy, Brass, Steel	17	STANDARD - FLAT	07150-03005	12.19	33.02	6.10	17	STANDARD - RECESSED	07170-03005	12.19	33.53	10.41
	18	LONG - FLAT	07150-04005	12.19	58.42	6.10	18	LONG - RECESSED	07170-03205	12.19	58.42	10.41
	18	LONG CURVED - FLAT	07150-05005	12.19	56.64	6.10	18	LONG CURVED - RECESSED	07170-03305	12.19	56.64	10.41
5/32" BRIV® St. Steel only	19	STANDARD - FLAT	07150-03005	12.19	33.02	6.10	19	STANDARD - RECESSED	07170-03005	12.19	33.53	10.41
	20	LONG - FLAT	07150-04005	12.19	58.42	6.10	20	LONG - RECESSED	07170-03205	12.19	58.42	10.41
	20	LONG CURVED - FLAT	07150-05005	12.19	56.64	6.10	20	LONG CURVED - RECESSED	07170-03305	12.19	56.64	10.41
3/16" BRIV® Al. Alloy, Brass, Steel	21	STANDARD - FLAT	07150-03006	14.22	29.97	8.38	21	STANDARD - RECESSED	07170-03006	14.22	30.48	11.94
	22	LONG - FLAT	07150-04006	14.22	58.42	8.38	22	LONG - RECESSED	07170-03206	14.22	58.42	11.94
	22	LONG CURVED - FLAT	07150-05006	14.22	56.13	8.38	22	LONG CURVED - RECESSED	07170-03306	14.22	56.13	11.94
3/16" BRIV® St. Steel only	23	STANDARD - FLAT	07150-03006	14.22	29.97	8.38	23	STANDARD - RECESSED	07170-03006	14.22	30.48	11.94
	24	LONG - FLAT	07150-04006	14.22	58.42	8.38	24	LONG - RECESSED	07170-03206	14.22	58.42	11.94
	24	LONG CURVED - FLAT	07150-05006	14.22	56.13	8.38	24	LONG CURVED - RECESSED	07170-03306	14.22	56.13	11.94
6mm BRIV® Al. Alloy, Steel	25	STD. CAM OPERATED	07170-05600	16.33	30.65	13.14	25	STANDARD - FLAT	07170-05800	16.33	30.65	13.14
	26	LONG CAM OPERATED	07170-05700	16.33	55.65	13.14	26	LONG - FLAT	07170-05900	16.33	55.65	13.14
3/32" AVLUG®	27	STANDARD - FLAT	07150-03003	9.14	33.02	4.06	27	STANDARD - TAPERED	07150-03103	9.14	33.02	4.06
	27	STD. CAM OPERATED - FLAT	07170-04500	9.14	33.02	4.06	28	LONG - FLAT	07150-04003	10.41	58.42	4.06
	28	LONG CURVED - FLAT	07150-05003	10.41	57.91	4.06	-	-	-	-	-	-
	29	STANDARD - FLAT	07150-03004	10.41	29.97	5.08	29	STANDARD - TAPERED	07170-03104	10.41	30.23	5.08
1/8" AVLUG®	29	STD. CAM OPERATED - FLAT	07170-04600	10.41	29.97	5.08	30	LONG - FLAT	07150-04004	10.41	55.37	5.08
	30	LONG CURVED - FLAT	07150-05004	10.41	53.85	5.08	30	LONG CAM OPERATED - FLAT	07170-05000	10.41	55.37	5.08
2.5mm AVSERT®	31	STANDARD - FLAT	07150-03003	9.14	33.02	4.06	-	-	-	-	-	-
3.0mm AVSERT®	32	STANDARD - FLAT	07150-03004	10.41	29.97	5.08	32	STD. CAM OPERATED - FLAT	07170-04600	10.41	29.97	5.08
2.5mm AVTRONIC®	33	STANDARD - FLAT	07150-03003	9.14	33.02	4.06	33	LTD. ACCESS CAM OPERATED	07271-08000	10.41	29.97	4.06
	34	LONG - FLAT	07150-04003	10.41	58.42	4.06	-	-	-	-	-	-
2.8mm AVTRONIC®	35	STANDARD - FLAT	07271-05600	9.14	33.02	4.06	36	LTD. ACCESS CAM OPERATED	07271-08100	10.16	29.97	4.06
	37	LONG - FLAT	07271-05900	10.41	58.42	4.06	-	-	-	-	-	-
2.8mm RIVSCREW®	38	STD. CAM OPERATED - HF	07271-03000	10.41	29.97	6.10	-	-	-	-	-	-
3.0mm RIVSCREW®	39	STD. CAM OPERATED - HF	07271-03000	10.41	29.97	6.10	-	-	-	-	-	-
3.5mm RIVSCREW®	40	STD. CAM OPERATED - HF	07271-03500	10.41	29.97	6.10	-	-	-	-	-	-
4.0mm RIVSCREW®	41	STD. CAM OPERATED - HF	07271-04000	10.41	29.97	6.35	-	-	-	-	-	-

These nose jaws are suitable for placing Chobert® rivets with a Universal Head Form. When used on the equivalent size of Briv®, the highest possible clench is achieved. Note that when using Briv® fasteners, the maximum grip is reduced by approximately 0.015" (0.4mm).

Nose Assemblies

Mandrels and Mandrel Follower Springs

Mandrels and mandrel follower springs, illustrated on page 11 need to be selected to suit the fastener type and size as well as the size of the hole in the application. Use of the wrong mandrel could increase the risk of breakage and the wear of the mandrel head. Feeding problems could occur if the wrong mandrel follower spring is used.

I M P O R T A N T

READ THE SAFETY INSTRUCTIONS page 4 carefully.

While a small amount of wear and marking will naturally occur through normal and correct use of mandrels, they must be regularly examined for excessive wear and marking, with particular attention to the head diameter, the tail jaw gripping area of the shank or heavy pitting of the shank and any mandrel distortion. Mandrels which fail during use could forcibly exit the tool. It is the customer's responsibility to ensure that mandrels are replaced before any excessive levels of wear and always before the maximum recommended number of placings. Contact your Avdel representative who will let you know what that figure is by measuring the broach load of your application with our calibrated measuring tool. These tools can also be purchased under part number 07900-09080, supplied with all necessary information for testing.

Chobert® and Grovit® - Imperial

For mandrel or mandrel follower spring selection, follow instructions on page 18.

FASTENER	REF. N°	HOLE SIZE	STANDARD MANDREL - GREEN				HOLE SIZE	1ST OVERSIZE MANDREL - YELLOW				SPRING PART N°		
			HEAD Ø	MANDREL PART N°	P MAX.	# S/R MANDREL PART N°		P MAX.	HEAD Ø	MANDREL PART N°	P MAX.		# S/R MANDREL PART N°	P MAX.
3/32" CHOBERT® & GROVIT®	1	AS REC.	.0725	07150-06003	.166	07150-08003	.071	+0.015	.074	07150-06303	.174	-	-	07150-06803
	1	-	-	-	-	-	-	+0.035	.076	-	-	07150-08103	.078	07150-06803
	2	AS REC.	.0725	07150-06003	.166	07150-08003	.071	+0.015	.074	07150-06303	.174	-	-	07170-06873
	2	-	-	-	-	-	-	+0.035	.076	-	-	07150-08103	.078	07170-06873
3/32" CHOBERT® & GROVIT®	3	AS REC.	.0725	07150-06003	.166	07150-08003	.071	+0.015	.074	07150-06303	.174	-	-	07170-06903
	3	-	-	-	-	-	-	+0.035	.076	-	-	07150-08103	.078	07170-06903
3/32" CHOBERT® & GROVIT®	4	AS REC.	.0725	07150-07003	.166	07150-09003	.071	+0.035	.076	-	-	07150-09103	.078	07150-07803
	4	-	-	-	-	-	-	-	-	-	-	-	-	-
1/8" CHOBERT® & GROVIT®	5	AS REC.	.088	07150-06004	.216	07150-08004	.090	+0.004	.092	07150-06104	.237	07150-08104	.098	07150-06804
	6	AS REC.	.088	07150-07004	.216	07150-09004	.090	+0.004	.092	07150-07104	.237	07150-09104	.098	07150-07804
5/32" CHOBERT® & GROVIT®	7	AS REC.	.107	07150-06005	.244	07150-08005	.100	+0.008	.115	07150-06105	.284	07150-08105	.116	07170-06875
	7	-	-	-	-	-	-	-	-	-	-	-	-	-
	8	AS REC.	.107	07150-07005	.244	07150-09005	.100	+0.008	.115	07150-07105	.284	07150-09105	.116	07170-07875
	8	-	-	-	-	-	-	-	-	-	-	-	-	-
3/16" CHOBERT® & GROVIT®	9	AS REC.	.132	07150-06006	.247	07150-08006	.102	+0.014	.146	07150-06106	.320	07150-08106	.130	07170-06876
	9	-	-	-	-	-	-	-	-	-	-	-	-	-
	10	AS REC.	.132	07150-07006	.247	07150-09006	.102	+0.014	.146	07150-07106	.320	07150-09106	.130	07170-07876
1/4" CHOBERT®	11	AS REC.	.184	07150-06008	.268	07150-08008	.110	+0.012	.196	07150-06108	.330	07150-08108	.134	07150-06808
	12	AS REC.	.184	07150-07008	.268	07150-09008	.110	+0.012	.196	07150-07108	.330	07150-09108	.134	07150-07808

FASTENER	REF. N°	HOLE SIZE	2ND OVERSIZE MANDREL - BLUE				HOLE SIZE	3RD OVERSIZE MANDREL - RED				SPRING PART N°		
			HEAD Ø	MANDREL PART N°	P MAX.	# S/R MANDREL PART N°		P MAX.	HEAD Ø	MANDREL PART N°	P MAX.		# S/R MANDREL PART N°	P MAX.
3/32" CHOBERT® & GROVIT®	1	+0.035	.076	07150-06103	.185	-	-	-	-	-	-	-	-	07150-06803
	1	-	-	-	-	-	-	-	-	-	-	-	-	-
	2	+0.035	.076	07150-06103	.185	-	-	-	-	-	-	-	-	07170-06873
	2	-	-	-	-	-	-	-	-	-	-	-	-	-
3/32" CHOBERT® & GROVIT®	3	+0.035	.076	07150-06103	.185	-	-	-	-	-	-	-	-	07170-06903
	3	-	-	-	-	-	-	-	-	-	-	-	-	-
3/32" CHOBERT® & GROVIT®	4	+0.035	.076	07150-07103	.185	-	-	-	-	-	-	-	-	07150-07803
	4	-	-	-	-	-	-	-	-	-	-	-	-	-
1/8" CHOBERT® & GROVIT®	5	+0.010	.098	07150-06204	.268	07150-08204	.110	+0.014	.102	07150-06304	.288	07150-08304	.118	07150-06804
	6	+0.010	.098	07150-07204	.268	07150-09204	.110	+0.014	.102	07150-07304	.288	07150-09304	.118	07150-07804
5/32" CHOBERT® & GROVIT®	7	+0.015	.122	07150-06205	.320	07150-08205	.130	-	-	-	-	-	-	07170-06875
	7	-	-	-	-	-	-	+0.025	.132	07150-06305	.372	07150-08305	.150	07150-06805
	8	+0.015	.122	07150-07205	.320	07150-09205	.130	-	-	-	-	-	-	07170-07875
	8	-	-	-	-	-	-	+0.025	.132	07150-07305	.372	07150-09305	.150	07150-07805
3/16" CHOBERT® & GROVIT®	9	-	-	-	-	-	-	-	-	-	-	-	-	-
	9	+0.024	.156	07150-06206	.372	07150-08206	.150	-	-	-	-	-	-	07150-06806
	10	-	-	-	-	-	-	-	-	-	-	-	-	-
3/16" CHOBERT® & GROVIT®	10	+0.024	.156	07150-07206	.372	07150-09206	.150	-	-	-	-	-	-	07150-07806
	10	-	-	-	-	-	-	-	-	-	-	-	-	-
1/4" CHOBERT®	11	-	-	-	-	-	-	-	-	-	-	-	-	-
	12	-	-	-	-	-	-	-	-	-	-	-	-	-

S/R: Short Reach Mandrel. See page 18-19 for explanation.

Nose Assemblies

Tables below left and right and over the next four pages list part numbers of all mandrels and mandrel follower springs available per fastener or group of fasteners, i.e. for Chobert® and Grovit® on these pages.

While fastener sizes are always shown in their specified units, each table has been produced twice to offer dimensions in imperial units on the left-hand page then in metric units on the right-hand page. These 'Mandrel Selection' tables cross-reference with the 'Nose Jaw Selection' tables on pages 14-15 through the 'Ref. N°' column.

It is the diameter of the head at the end of a mandrel which when pulled through controls the expansion of the fastener body.

While there are different head shapes to suit different types of fasteners (see illustration on page 19), progressive head sizes are needed to reflect manufacturing tolerances on the diameter of the hole in your application so that the fastener always expands sufficiently to fill the hole.

Too large a mandrel head would overstress the mandrel and mandrels which fail during use could forcibly exit the tool. Selection tables are arranged into four 'mandrel size' sections, ranging from 'standard' to '3rd oversize', each being colour coded as per the end of the mandrel heads themselves.

Chobert® and Grovit® - Metric

FASTENER	REF. N°	HOLE SIZE	STANDARD MANDREL - GREEN					HOLE SIZE	1ST OVERSIZE MANDREL - YELLOW					SPRING PART N°
			HEAD Ø	MANDREL PART N°	P MAX.	# S/R MANDREL PART N°	P MAX.		HEAD Ø	MANDREL PART N°	P MAX.	# S/R MANDREL PART N°	P MAX.	
3/32" CHOBERT® & GROVIT®	1	AS REC.	1.84	07150-06003	4.22	07150-08003	1.80	+04	1.88	07150-06303	4.42	-	-	07150-06803
	1	-	-	-	-	-	-	+09	1.93	-	-	07150-08103	1.98	07150-06803
	2	AS REC.	1.84	07150-06003	4.22	07150-08003	1.80	+04	1.88	07150-06303	4.42	-	-	07170-06873
	2	-	-	-	-	-	-	+09	1.93	-	-	07150-08103	1.98	07170-06873
	3	AS REC.	1.84	07150-06003	4.22	07150-08003	1.80	+04	1.88	07150-06303	4.42	-	-	07170-06903
	3	-	-	-	-	-	-	+09	1.93	-	-	07150-08103	1.98	07170-06903
	4	AS REC.	1.84	07150-07003	4.22	07150-09003	1.80	+09	1.93	-	-	07150-09103	1.98	07150-07803
1/8" CHOBERT® & GROVIT®	5	AS REC.	2.24	07150-06004	5.49	07150-08004	2.29	+10	2.34	07150-06104	6.02	07150-08104	2.49	07150-06804
	6	AS REC.	2.24	07150-07004	5.49	07150-09004	2.29	+10	2.34	07150-07104	6.02	07150-09104	2.49	07150-07804
5/32" CHOBERT® & GROVIT®	7	AS REC.	2.72	07150-06005	6.20	07150-08005	2.54	+20	2.92	07150-06105	7.21	07150-08105	2.95	07170-06875
	7	-	-	-	-	-	-	-	-	-	-	-	-	-
	8	AS REC.	2.72	07150-07005	6.20	07150-09005	2.54	+20	2.92	07150-07105	7.21	07150-09105	2.95	07170-07875
3/16" CHOBERT® & GROVIT®	9	AS REC.	3.35	07150-06006	6.27	07150-08006	2.59	+35	3.71	07150-06106	8.13	07150-08106	3.30	07170-06876
	9	-	-	-	-	-	-	-	-	-	-	-	-	-
	10	AS REC.	3.35	07150-07006	6.27	07150-09006	2.59	+35	3.71	07150-07106	8.13	07150-09106	3.30	07170-07876
	10	-	-	-	-	-	-	-	-	-	-	-	-	-
1/4" CHOBERT®	11	AS REC.	4.67	07150-06008	6.81	07150-08008	2.79	+30	4.98	07150-06108	8.38	07150-08108	3.40	07150-06808
	12	AS REC.	4.67	07150-07008	6.81	07150-09008	2.79	+30	4.98	07150-07108	8.38	07150-09108	3.40	07150-07808

FASTENER	REF. N°	HOLE SIZE	2ND OVERSIZE MANDREL - BLUE					HOLE SIZE	3RD OVERSIZE MANDREL - RED					SPRING PART N°
			HEAD Ø	MANDREL PART N°	P MAX.	# S/R MANDREL PART N°	P MAX.		HEAD Ø	MANDREL PART N°	P MAX.	# S/R MANDREL PART N°	P MAX.	
3/32" CHOBERT® & GROVIT®	1	+09	1.93	07150-06103	4.70	-	-	-	-	-	-	-	-	07150-06803
	1	-	-	-	-	-	-	-	-	-	-	-	-	-
	2	+09	1.93	07150-06103	4.70	-	-	-	-	-	-	-	-	07170-06873
	2	-	-	-	-	-	-	-	-	-	-	-	-	-
	3	+09	1.93	07150-06103	4.70	-	-	-	-	-	-	-	-	07170-06903
1/8" CHOBERT® & GROVIT®	4	-	-	-	-	-	-	-	-	-	-	-	-	-
	4	+09	1.93	07150-07103	4.70	-	-	-	-	-	-	-	-	07150-07803
	5	+25	2.49	07150-06204	6.81	07150-08204	2.79	+35	2.59	07150-06304	7.32	07150-08304	3.00	07150-06804
	6	+25	2.49	07150-07204	6.81	07150-09204	2.79	+35	2.59	07150-07304	7.32	07150-09304	3.00	07150-07804
5/32" CHOBERT® & GROVIT®	7	+38	3.10	07150-06205	8.13	07150-08205	3.30	-	-	-	-	-	-	07170-06875
	7	-	-	-	-	-	-	+63	3.35	07150-06305	9.45	07150-08305	3.81	07150-06805
	8	+38	3.10	07150-07205	8.13	07150-09205	3.30	-	-	-	-	-	-	07170-07875
	8	-	-	-	-	-	-	+63	3.35	07150-07305	9.45	07150-09305	3.81	07150-07805
3/16" CHOBERT® & GROVIT®	9	-	-	-	-	-	-	-	-	-	-	-	-	-
	9	+60	3.96	07150-06206	9.45	07150-08206	3.81	-	-	-	-	-	-	07150-06806
	10	-	-	-	-	-	-	-	-	-	-	-	-	-
1/4" CHOBERT®	10	+60	3.96	07150-07206	9.45	07150-09206	3.81	-	-	-	-	-	-	07150-07806
	11	-	-	-	-	-	-	-	-	-	-	-	-	-
	12	-	-	-	-	-	-	-	-	-	-	-	-	-

S/R: Short Reach Mandrel. See page 18-19 for explanation.

Nose Assemblies

To find the correct part number of a mandrel for a particular application, read the instructions below after you have gathered the following information as per example alongside. Answers for the example are shown in *grey italic*.

FASTENER NAME	<i>example</i>	<i>Chobert®</i>
FASTENER SIZE		<i>1/8"</i>
DATASHEET		<i>Series 1125</i>
APPLICATION HOLE SIZE		<i>0.1335"</i>
CLEARANCE BEHIND APPLICATION		<i>Infinite</i>
'REF.N°' FROM NOSE JAW SELECTION TABLE		<i>5 (standard flat)</i>

- Subtract the minimum hole size recommended (AS REC.) in the fastener datasheet from the actual application hole size. *-example: 0.005.*
- Turn to the page with the 'Mandrel Selection' table for your fastener, selecting either the imperial or the metric dimensions table (pages 16-20). *-example: page 16.*
- Starting with the 'Standard Mandrel - Green' section, find your fastener size in the left-hand column. *-example 1/8" Chobert® & Grovit®.*
- If you selected a nose jaw which place you fastener, you should now be able to find a line within your fastener section with the same 'Ref No.' as that from the 'Nose Jaw Selection' table. *-example: 5.* This is your line 'Ref. No.' in which you will find both your mandrel and mandrel follower spring part number. This line continues into the second half of the table for the '2nd' and '3rd' oversize mandrels.
- Scan along the line to the 'hole size' columns and select which ever is the nearest or equal to the figure calculated in step one. You may now read the mandrel part number next to the 'hole size'. *-example: 07150-06104*
- For Chobert® and Grovit® only, most mandrels are also available in a 'short reach' version (see illustration on page 19). Short reach mandrels are used to minimise the possibility of the mandrel head contacting an obstruction. This would result in the underside of the fastener head not seating properly on the application surface, causing a lack on clench in the joint.
- Whichever size mandrel you settle on, you will also need to check the 'P' figure against that mandrel is adequate. 'P' is the clearance required for the mandrel head at the back of the application IN ADDITION to the length of the fastener protruding through the application, as shown in the illustration on page 19.
- You may now read the corresponding mandrel follower spring part number in the right-hand column of the table. *-example: 07150-06804.*

In all cases, satisfactory clenching of the joint should be assessed particularly if the size of the hole in your application is very close to the next oversize hole condition, when it will be safe to select the greater size of mandrel to obtain a higher clench. REMEMBER that this will increase the broach load and reduce the mandrel life.

Briv® - Imperial

For mandrel or mandrel follower spring selection, follow instructions above.

FASTENER	REF. N°	HOLE SIZE	STANDARD MANDREL - GREEN			HOLE SIZE	1ST OVERSIZE MANDREL - YELLOW			SPRING PART N°
			HEAD Ø	MANDREL PART N°	P MAX.		HEAD Ø	MANDREL PART N°	P MAX.	
3/32" BRIV® Brass only	13	AS REC.	.072	07150-06013	.119	+0.04	.076	07150-06113	.123	07170-06873
	14	AS REC.	.072	07150-06013	.119	+0.04	.076	07150-06113	.123	07170-06903
1/8" BRIV® Al. Alloy, Brass, Steel	15	AS REC.	.092	07271-06414	.120	+0.05	.097	07271-06514	.126	07150-06814
	16	AS REC.	.092	07271-07414	.120	+0.05	.097	07271-07514	.126	07150-07814
5/32" BRIV® Al. Alloy, Brass, Steel	17	AS REC.	.110	07150-06015	.136	+0.05	.115	07150-06115	.142	07170-06875
	18	AS REC.	.110	07150-07015	.136	+0.05	.115	07150-07115	.142	07170-07875
5/32" BRIV® St.Steel only	19	AS REC.	.120	07170-06805	.126	+0.05	.125	07170-06825	.132	07170-06875
	20	AS REC.	.120	07170-07805	.126	+0.05	.125	07170-07825	.132	07170-07875
3/16" BRIV® Al. Alloy, Brass, Steel	21	AS REC.	.141	07150-06016	.157	+0.05	.146	07150-06116	.164	07170-06876
	22	AS REC.	.141	07150-07016	.157	+0.05	.146	07150-07116	.164	07170-07876
3/16" BRIV® St.Steel only	23	AS REC.	.153	07170-06806	.150	+0.05	.158	07170-06826	.156	07170-06876
	24	AS REC.	.153	07170-07806	.150	+0.05	.158	07170-07826	.156	07170-07876
6mm BRIV® Al. Alloy, Steel	25	AS REC.	.179	07150-06018	.165	+0.05	.184	07150-06118	.171	07150-06846
	26	AS REC.	.179	07150-07018	.165	+0.05	.184	07150-07118	.171	07150-07846

FASTENER	REF. N°	HOLE SIZE	2ND OVERSIZE MANDREL - BLUE			HOLE SIZE	3RD OVERSIZE MANDREL - RED			SPRING PART N°
			HEAD Ø	MANDREL PART N°	P MAX.		HEAD Ø	MANDREL PART N°	P MAX.	
3/32" BRIV® Brass only	13	+0.08	.079	07150-06213	.126	-	-	-	-	07170-06873
	14	+0.08	.079	07150-06213	.126	-	-	-	-	07170-06903
1/8" BRIV® Al. Alloy, Brass, Steel	15	+0.10	.102	07271-06614	.133	-	-	-	-	07150-06814
	16	+0.10	.102	07271-07614	.133	-	-	-	-	07150-07814
5/32" BRIV® Al. Alloy, Brass, Steel	17	+0.10	.120	07150-06215	.149	-	-	-	-	07170-06875
	18	+0.10	.120	07150-07215	.149	-	-	-	-	07170-07875
5/32" BRIV® St.Steel only	19	-	-	-	-	-	-	-	-	-
	20	-	-	-	-	-	-	-	-	-
3/16" BRIV® Al. Alloy, Brass, Steel	21	+0.10	.151	07150-06216	.170	+0.12	.153	07150-06316	.173	07170-06876
	22	+0.10	.151	07150-07216	.170	+0.12	.153	07150-07316	.173	07170-07876
3/16" BRIV® St.Steel only	23	-	-	-	-	-	-	-	-	-
	24	-	-	-	-	-	-	-	-	-
6mm BRIV® Al. Alloy, Steel	25	+0.10	.189	07150-06218	.177	-	-	-	-	07150-06846
	26	+0.10	.189	07150-07218	.177	-	-	-	-	07150-07846

Nose Assemblies

Mandrel Head Types and 'P' Length

Mandrels for stainless steel Briv® are easily identifiable by a 'V' cut in the end of the mandrel heads.

When using curved nose jaws, mandrels have to be bent by hand to match the curvature of the nose jaw, thus ensuring good feed of fasteners.

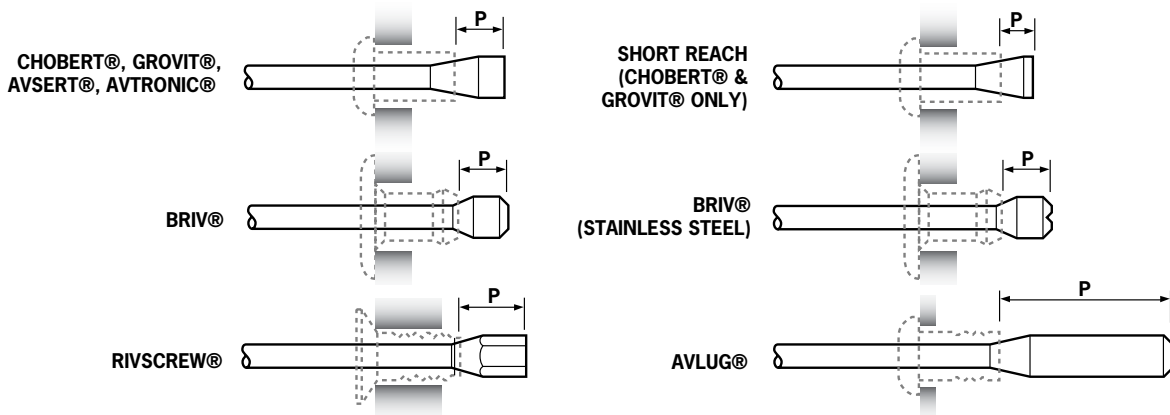

Briv® - Metric

FASTENER	REF. N°	HOLE SIZE	STANDARD MANDREL - GREEN			HOLE SIZE	1ST OVERSIZE MANDREL - YELLOW			SPRING PART N°
			HEAD Ø	MANDREL PART N°	P MAX.		HEAD Ø	MANDREL PART N°	P MAX.	
2.4mm BRIV® Brass only	13	AS REC.	1.83	07150-06013	3.02	+10	1.93	07150-06113	3.12	07170-06873
	14	AS REC.	1.83	07150-06013	3.02	+10	1.93	07150-06113	3.12	07170-06903
3.2mm BRIV® Al. Alloy, Brass, Steel	15	AS REC.	2.34	07271-06414	3.05	+13	2.46	07271-06514	3.20	07150-06814
	16	AS REC.	2.34	07271-07414	3.05	+13	2.46	07271-07514	3.20	07150-07814
4.0mm BRIV® Al. Alloy, Brass, Steel	17	AS REC.	2.79	07150-06015	3.45	+13	2.92	07150-06115	3.61	07170-06875
	18	AS REC.	2.79	07150-07015	3.45	+13	2.92	07150-07115	3.61	07170-07875
4.0mm BRIV® St. Steel only	19	AS REC.	3.05	07170-06805	3.20	+13	3.18	07170-06825	3.35	07170-06875
	20	AS REC.	3.05	07170-07805	3.20	+13	3.18	07170-07825	3.35	07170-07875
4.8mm BRIV® Al. Alloy, Brass, Steel	21	AS REC.	3.58	07150-06016	3.99	+13	3.71	07150-06116	4.17	07170-06876
	22	AS REC.	3.58	07150-07016	3.99	+13	3.71	07150-07116	4.17	07170-07876
4.8mm BRIV® St. Steel only	23	AS REC.	3.89	07170-06806	3.81	+13	4.01	07170-06826	3.96	07170-06876
	24	AS REC.	3.89	07170-07806	3.81	+13	4.01	07170-07826	3.96	07170-07876
6mm BRIV® Al. Alloy, Steel	25	AS REC.	4.54	07150-06018	4.18	+13	4.67	07150-06118	4.34	07150-06846
	26	AS REC.	4.54	07150-07018	4.18	+13	4.67	07150-07118	4.34	07150-07846

FASTENER	REF. N°	HOLE SIZE	2ND OVERSIZE MANDREL - BLUE			HOLE SIZE	3RD OVERSIZE MANDREL - RED			SPRING PART N°
			HEAD Ø	MANDREL PART N°	P MAX.		HEAD Ø	MANDREL PART N°	P MAX.	
2.4mm BRIV® Brass only	13	+20	2.01	07150-06213	3.20	-	-	-	-	07170-06873
	14	+20	2.01	07150-06213	3.20	-	-	-	-	07170-06903
3.2mm BRIV® Al. Alloy, Brass, Steel	15	+25	2.59	07271-06614	3.38	-	-	-	-	07150-06814
	16	+25	2.59	07271-07614	3.38	-	-	-	-	07150-07814
4.0mm BRIV® Al. Alloy, Brass, Steel	17	+25	3.05	07150-06215	3.78	-	-	-	-	07170-06875
	18	+25	3.05	07150-07215	3.78	-	-	-	-	07170-07875
4.0mm BRIV® St. Steel only	19	-	-	-	-	-	-	-	-	-
	20	-	-	-	-	-	-	-	-	-
4.8mm BRIV® Al. Alloy, Brass, Steel	21	+25	3.84	07150-06216	4.32	+30	3.85	07150-06316	4.39	07170-06876
	22	+25	3.84	07150-07216	4.32	+30	3.85	07150-07316	4.39	07170-07876
4.8mm BRIV® St. Steel only	23	-	-	-	-	-	-	-	-	-
	24	-	-	-	-	-	-	-	-	-
6mm BRIV® Al. Alloy, Steel	25	+25	4.79	07150-06218	4.49	-	-	-	-	07150-06846
	26	+25	4.79	07150-07218	4.49	-	-	-	-	07150-07846

Nose Assemblies

Avlug®, Avsert®, Avtronic® and Rivscrew® - Imperial and Metric

For mandrel or mandrel follower spring selection, follow instructions on page 18.

FASTENER	REF. N°	HOLE SIZE	STANDARD MANDREL - GREEN			HOLE SIZE	1ST OVERSIZE MANDREL - YELLOW			SPRING PART N°
			HEAD Ø	MANDREL PART N°	P MAX.		HEAD Ø	MANDREL PART N°	P MAX.	
3/32" AVLUG®	27	AS REC.	.076	07150-06603	.353	+0.05	.081	07150-06703	.478	07150-06803
	28	AS REC.	.076	07150-07603	.353	+0.003	.079	07150-07703	.368	07150-07803
1/8" AVLUG®	29	AS REC.	.098	07150-06604	.593	-	-	-	-	07150-06804
	30	AS REC.	.098	07150-07604	.593	-	-	-	-	07150-07804
2.5mm, 4-40 UNC AVSERT®	31	AS REC.	.0725	07150-06003	.145	-	-	-	-	07150-06803
3.0mm, 6-32 UNC AVSERT®	32	AS REC.	.088	07150-06004	.185	-	-	-	-	07150-06804
2.5mm AVTRONIC®	33	AS REC.	.070	07170-06025	.140	+0.003	.073	07170-06125	.140	07150-06803
	34	AS REC.	.070	07170-07025	.140	+0.003	.073	07170-07125	.140	07150-07803
2.8mm AVTRONIC®	35	AS REC.	.079	07170-06028	.150	+0.003	.082	07170-06128	.150	07170-06528
	36	AS REC.	.079	07170-06028	.150	+0.003	.082	07170-06128	.150	07170-06873
2.8mm RIVSCREW®	37	AS REC.	.079	07170-07028	.150	+0.003	.082	07170-07128	.150	07170-07528
	38	AS REC.	* .065	07271-06030	.127	-	-	-	-	07271-06630
3.0mm RIVSCREW®	39	AS REC.	* .065	07271-06030	.127	-	-	-	-	07271-06630
3.5mm RIVSCREW®	40	AS REC.	* .0825	07271-06035	.132	-	-	-	-	07271-06635
4.0mm RIVSCREW®	41	AS REC.	* .103	07271-06140	.150	-	-	-	-	07271-06640

* These Dimensions are Across Flats

FASTENER	REF. N°	HOLE SIZE	2ND OVERSIZE MANDREL - BLUE			HOLE SIZE	3RD OVERSIZE MANDREL - RED			SPRING PART N°
			HEAD Ø	MANDREL PART N°	P MAX.		HEAD Ø	MANDREL PART N°	P MAX.	
3/32" AVLUG®	27	-	-	-	-	-	-	-	-	-
	28	-	-	-	-	-	-	-	-	-
1/8" AVLUG®	29	-	-	-	-	-	-	-	-	-
	30	-	-	-	-	-	-	-	-	-
2.5mm, 4-40 UNC AVSERT®	31	-	-	-	-	-	-	-	-	-
3.0mm, 6-32 UNC AVSERT®	32	-	-	-	-	-	-	-	-	-
2.5mm AVTRONIC®	33	+0.006	.076	07170-06225	.140	-	-	-	-	07150-06803
	34	+0.006	.076	07170-07225	.140	-	-	-	-	07150-07803
2.8mm AVTRONIC®	35	+0.006	.085	07170-06228	.150	-	-	-	-	07170-06528
	36	+0.006	.085	07170-06228	.150	-	-	-	-	07170-06873
2.8mm RIVSCREW®	37	+0.006	.085	07170-07228	.150	-	-	-	-	07170-07528
	38	-	-	-	-	-	-	-	-	-
3.0mm RIVSCREW®	39	-	-	-	-	-	-	-	-	-
3.5mm RIVSCREW®	40	-	-	-	-	-	-	-	-	-
4.0mm RIVSCREW®	41	-	-	-	-	-	-	-	-	-

FASTENER	LINE N°	HOLE SIZE	STANDARD MANDREL - GREEN			HOLE SIZE	1ST OVERSIZE MANDREL - YELLOW			SPRING PART N°
			HEAD Ø	MANDREL PART N°	P MAX.		HEAD Ø	MANDREL PART N°	P MAX.	
3/32" AVLUG®	27	AS REC.	1.93	07150-06603	8.97	+10	2.06	07150-06703	12.14	07150-06803
	28	AS REC.	1.93	07150-07603	8.97	+10	2.01	07150-07703	9.35	07150-07803
1/8" AVLUG®	29	AS REC.	2.49	07150-06604	15.06	-	-	-	-	07150-06804
	30	AS REC.	2.49	07150-07604	15.06	-	-	-	-	07150-07804
2.5mm, 4-40 UNC AVSERT®	31	AS REC.	1.84	07150-06003	3.68	-	-	-	-	07150-06803
3.0mm, 6-32 UNC AVSERT®	32	AS REC.	2.24	07150-06004	4.70	-	-	-	-	07150-06804
2.5mm AVTRONIC®	33	AS REC.	1.78	07170-06025	3.56	+07	1.85	07170-06125	3.56	07150-06803
	34	AS REC.	1.78	07170-07025	3.56	+07	1.85	07170-07125	3.56	07150-07803
2.8mm AVTRONIC®	35	AS REC.	2.01	07170-06028	3.81	+07	2.08	07170-06128	3.81	07170-06528
	36	AS REC.	2.01	07170-06028	3.81	+07	2.08	07170-06128	3.81	07170-06873
2.8mm RIVSCREW®	37	AS REC.	2.01	07170-07028	3.81	+07	2.08	07170-07128	3.81	07170-07528
	38	AS REC.	* 1.65	07271-06030	3.23	-	-	-	-	07271-06630
3.0mm RIVSCREW®	39	AS REC.	* 1.65	07271-06030	3.23	-	-	-	-	07271-06630
3.5mm RIVSCREW®	40	AS REC.	* 2.10	07271-06035	3.35	-	-	-	-	07271-06635
4.0mm RIVSCREW®	41	AS REC.	* 2.62	07271-06140	3.81	-	-	-	-	07271-06640

* These Dimensions are Across Flats

FASTENER	LINE N°	HOLE SIZE	2ND OVERSIZE MANDREL - BLUE			HOLE SIZE	3RD OVERSIZE MANDREL - RED			SPRING PART N°
			HEAD Ø	MANDREL PART N°	P MAX.		HEAD Ø	MANDREL PART N°	P MAX.	
3/32" AVLUG®	27	-	-	-	-	-	-	-	-	-
	28	-	-	-	-	-	-	-	-	-
1/8" AVLUG®	29	-	-	-	-	-	-	-	-	-
	30	-	-	-	-	-	-	-	-	-
2.5mm, 4-40 UNC AVSERT®	31	-	-	-	-	-	-	-	-	-
3.0mm, 6-32 UNC AVSERT®	32	-	-	-	-	-	-	-	-	-
2.5mm AVTRONIC®	33	+15	1.93	07170-06225	3.56	-	-	-	-	07150-06803
	34	+15	1.93	07170-07225	3.56	-	-	-	-	07150-07803
2.8mm AVTRONIC®	35	+15	2.16	07170-06228	3.81	-	-	-	-	07170-06528
	36	+15	2.16	07170-06228	3.81	-	-	-	-	07170-06873
2.8mm RIVSCREW®	37	+15	2.16	07170-07228	3.81	-	-	-	-	07170-07528
	38	-	-	-	-	-	-	-	-	-
3.0mm RIVSCREW®	39	-	-	-	-	-	-	-	-	-
3.5mm RIVSCREW®	40	-	-	-	-	-	-	-	-	-
4.0mm RIVSCREW®	41	-	-	-	-	-	-	-	-	-

Servicing the Tool

Regular servicing should be carried out and a comprehensive inspection performed annually or every 500,000 cycles, whichever is sooner.

I M P O R T A N T

**The employer is responsible for ensuring that tool maintenance instructions are given to the appropriate personnel.
The operator should not be involved in maintenance or repair of the tool unless properly trained.**

Daily

- Daily, before use or when first putting the tool into service. Pour a few drops of clean lubricating oil into the air inlet of the tool if no lubricator is fitted on air supply. If the tool is in continuous use, the air hose should be disconnected from the main air supply and the tool lubricated every two to three hours.
- Check for air and oil leaks. If damaged, hoses and couplings should be replaced.
- If there is no filter on the pressure regulator, bleed the airline to clear it of accumulated dirt or water before connecting the air hose to the intensifier. If there is a filter, drain it.
- Check that the nose equipment is correct.
- Check mandrels regularly for signs of wear or damage monitoring the number of placings (read the safety instructions on page 4).
- Check the base cover is fully tightened onto the body.

Weekly

- Conduct the full "Daily" procedures as described above.
- Remove, inspect, clean and grease the Tail Jaws (refer to "Tail Jaw Cylinder" in the "Maintenance Section" page 24).

MolyLithium Grease EP 3753 Safety Data

Grease can be ordered as a single item, the part number is shown in the Service Kits page 23.

First Aid

SKIN:

As the grease is completely water resistant it is best removed with an approved emulsifying skin cleaner.

INGESTION:

Ensure the individual drinks 30ml Milk of Magnesia, preferably in a cup of milk.

EYES:

Irritant but not harmful. Irrigate with water and seek medical attention.

Fire

FLASH POINT: Above 220°C.

Not classified as flammable.

Suitable extinguishing media: CO₂, Halon or water spray if applied by an experienced operator.

Environment

Scrape up for burning or disposal on approved site.

Handling

Use barrier cream or oil resistant gloves

Storage

Away from heat and oxidising agent.

Servicing the Tool

Molykote® 55m Grease Safety Data

First Aid

SKIN:

Flush with water. Wipe off.

INGESTION:

No first aid should be needed.

EYES:

Flush with water.

Fire

FLASH POINT: Above 101.1°C. (closed cup)

Explosive Properties: No

Suitable Extinguishing Media: Carbon Dioxide Foam, Dry Powder or fine water spray.

Water can be used to cool fire exposed containers.

Environment

Do not allow large quantities to enter drains or surface waters.

Methods for cleaning up: Scrape up and place in suitable container fitted with a lid. The spilled product produces an extremely slippery surface.

Harmful to aquatic organisms and may cause long-term adverse effects in the aquatic environment. However, due to the physical form and water - insolubility of the product the bioavailability is negligible.

Handling

General ventilation is recommended. Avoid skin and eye contact.

Storage

Do not store with oxidizing agents. Keep container closed and store away from water or moisture.

Molykote® 111 Grease Safety Data

First Aid

SKIN:

No first aid should be needed.

INGESTION:

No first aid should be needed.

EYES:

No first aid should be needed.

INHALATION:

No first aid should be needed.

Fire

FLASH POINT: Above 101.1°C. (closed cup)

Explosive Properties: No

Suitable Extinguishing Media: Carbon Dioxide Foam, Dry Powder or fine water spray.

Water can be used to cool fire exposed containers.

Environment

No adverse effects are predicted.

Handling

General ventilation is recommended. Avoid eye contact.

Storage

Do not store with oxidizing agents. Keep container closed and store away from water or moisture.

Servicing the Tool

Service Kits

For all servicing we recommend the use of the following service kits.

SERVICE KIT : 07900-05300			Spanners are specified in inches and across flats unless otherwise stated.		
ITEM PART N°	DESCRIPTION	N° OFF	ITEM PART N°	DESCRIPTION	N° OFF
07900-00157	CIRCLIP PLIERS	1	07900-00352	SEAL REMOVAL HOOK	1
07900-00006	SPATULA	1	07900-00710	BARREL PLUG REMOVAL SPANNER	1
07900-00446	EXTRACTOR	1	07900-00725	BULLET	1
07900-00603	BARREL VICE JAWS	1	07900-00243	SCREWDRIVER	1
07900-00520	3/8" ROD	1	07900-00717	INTENSIFIER SPANNER	1
07900-00521	1/4" ROD	1	07900-00013	1/8" ALLEN KEY	1
07900-00602	'O' RING ASSEMBLY BULLET	1	07900-00617	LOCTITE® MULTI-GASKET 574 50ml PACK	1
07900-00595	18mm SPANNER	1	07900-00469	2.5mm ALLEN KEY	1
07900-00434	32mm SPANNER	1	07900-00351	3mm ALLEN KEY	1
07900-00237	3/8" x 5/16" B.S.W. SPANNER	1	07900-00224	4mm ALLEN KEY	1
07900-00012	9/16" x 5/8" SPANNER	1	07900-00225	5mm ALLEN KEY	1
07900-00008	7/16" x 1/2" SPANNER	1	07992-00020	80g TIN MOLYLITHIUM GREASE EP 3753	1

SERVICE KIT : 71210-99990			Spanners are specified in inches and across flats unless otherwise stated.		
PART N°	DESCRIPTION	N° OFF	PART N°	DESCRIPTION	N° OFF
07900-00667	PISTON SLEEVE	1	07900-00157	CIRCLIP PLIERS	1
07900-00692	TRIGGER VALVE EXTRACTOR	1	07900-00008	7/16 x 1/2 SPANNER	1
07900-00670	BULLET	1	07900-00012	9/16 x 5/8 SPANNER	1
07900-00672	'T' SPANNER	1	07900-00015	5/8 x 11/16 SPANNER	1
07900-00706	'T' SPANNER SPIGOT	1	07900-00686	PEG SPANNER	1
07900-00684	GUIDE TUBE	1	07900-00677	SEAL EXTRACTOR	1
07900-00685	INSERTION ROD	1	07900-00698	STOP NUT	1
07900-00351	3 MM ALLEN KEY	1	07900-00700	PRIMING PUMP	1
07900-00469	2.5 MM ALLEN KEY	1	07992-00020	GREASE - MOLY LITHIUM E.P.3753	1
07900-00158	2 MM PIN PUNCH	1	07992-00075	GREASE - MOLYKOTE® 55M	1
			07900-00775	GREASE - MOLYKOTE® 111	1

Maintenance

Every 500,000 cycles the tool should be completely dismantled and new components should be used where worn, damaged or when recommended. All 'O' rings and seals should be renewed and lubricated with Molykote® 55m grease for pneumatic sealing or Molykote® III for hydraulic sealing.

I M P O R T A N T

Safety Instructions appear on page 4.

**The employer is responsible for ensuring that tool maintenance instructions are given to the appropriate personnel.
The operator should not be involved in maintenance or repair of the tool unless properly trained.**

The airline must be disconnected before any servicing or dismantling is attempted, unless specifically instructed otherwise.

It is recommended that any dismantling operation be carried out in clean conditions.

Prior to dismantling the tool, you will need to remove the nose equipment.

For total tool servicing we advise that you proceed with the dismantling of sub-assemblies in the order shown.

Dismantling 07537-00200

REMOVAL OF THE HEAD MOULDINGS

- Manually flip the Clip **48** up and remove the End Cap **50**.
- Using an Allen Key*, remove the three securing Screws **2** and Nuts **7** from the tool body assembly and one Screw **97** from the LH Body Moulding **60**.
- Remove the RH and LH Body Moulding **59** and **60**.
- Assemble in reverse order of dismantling.

PNEUMATIC PISTON ASSEMBLY

- Clamp the Body **72** of the inverted tool across the air inlet bosses in a vice fitted with soft jaws.
- Pull off the Rubber Boot **67**.
- Using the peg spanner* unscrew Base Cover **73**.
- Unscrew Locknuts **6** (2 off) and remove the Base Plate **77**.
- Remove the Cylinder Liner **75**, together with Sealing Washers **78** (2 off) and 'O' Rings **9** (2 off).
- Remove Pneumatic Piston Assembly **58** from Body **72** together with 'O' Ring, Lip Seal (3 off) and Guide Ring.
- Assemble in reverse order.

VALVE SPOOL ASSEMBLY

- Remove Pneumatic Piston Assembly **58** and Intensifier Seal Assembly **71** as described immediately above.
- Using the 'T' spanner* and 'T' spanner spigot* undo Clamp Nut **64** and remove it together with Top Plate **76**, Tie Rods **74** and Transfer Tube Assembly **69**.
- Release the tool from the vice and separate Body **72** with 'O' Ring **20** from Handle Assembly **57**.
- Pull off the Head Assembly **56** from Handle Assembly **57** and remove 'O' Ring **19** from the intensifier tube.
- Push out Valve Seat **62** together with both 'O' Rings **18** (2 off).
- Remove all the components of Valve Spool Assembly **68**.
- Finally remove 'O' Ring **18** out of the handle counter bore.
- Assemble in reverse order to dismantling ensuring that the central port in Valve Seat **62** faces upwards towards "O" Ring **17**.

TRIGGER

- Using the 2 millimeter diameter pin punch*, drive Trigger Pin **65** out and lift off Trigger **61**.
- Unscrew Trigger Valve **24** using the trigger valve extractor*.
- Assemble in reverse order to dismantling.

* Refers to items included in the service kits 07900-05300 & 71210-99990. For complete list see page 23.
Item numbers in **bold** refer to the general assemblies and parts lists on pages 26-27.

Maintenance

Dismantling 07537-00200

TAIL JAW CYLINDER

- Using an Allen Key*, remove one cap head Screw **5** ensuring that any trapped air in the tail jaw cylinder is exhausted. Remove the second cap head Screw **5**.
- Pull out Rear Plug **47**.
- Extract air tail jaw components, comprising Tail Jaw Piston Assembly **51**, Spring **35**, Jaws **34** and Jaw Housing **41**.
- Remove plug at rear of piston assembly using an Allen Key* and a bar through the large slot in the turret.
- Clean out turret using a 4.7mm (3/16") drill and replace plug using a non-hardening sealing compound, e.g. Loctite® Multi-gasket 574*.
- Remove piston seal 'O' Ring **10**.
- Grip Barrel **44** in a vice using soft jaws* to avoid damage.
- Using a box spanner*, unscrew Barrel Plug **45**, preventing Barrel **44** turning by using an open ended spanner*.
- Disconnect Air Tail Jaw Concertina Tube **54** from Head Assembly and pull Tail Jaw Cylinder **46** from tool.
- Remove 'O' Ring **13**, Rubbing Strip **40** and Barrel Return Spring **37**.
- Free length of Spring **35** should be 38.1mm (1.5"). Replace if necessary.
- Coat the tail jaws with Moly Lithium grease before assembling.
- Assemble in reverse order of dismantling.

HYDRAULIC PISTON

- Remove Tail Jaw Cylinder **46** as described earlier.
- Grip Head Assembly **56** in vice using soft jaws* to avoid damage, undo Stroke Limiter **39**.
- Using an Allen Key*, loosen Screw **3** clamping the Switch Block **55** to the Barrel **44**.
- Using an Allen Key*, remove the Switch Block **55** & O Ring **21**, by undoing the securing Screw **4**.
- Hold the tool firmly and pull the Barrel **44** from the body (a small quantity of hydraulic oil may be ejected from inside body).
- Remove Piston **38** carefully so as not to damage body bore.
- Remove Lip Seal **15**.
- Lip Seal **16** is difficult to remove without damaging, but can remain in place during cleaning (provided it is not affected by cleaning process). If however, Lip Seal **16** requires renewing proceed as follows:
- Using spatula*, prise out Lip Seal **16** from Head Assembly **56**, taking care not to damage head cavity and bores. The removed Lip Seal **16** MUST be discarded.
- To replace Lip Seal **16**, unscrew existing Bleed Plug **43** until inside face is level with internal bore of the Head Assembly **56**. This will provide a smooth passage for insertion of new Lip Seal **16** through rear of body.
- Ensure the Lip Seal **16** is well greased and the correct way round with the open end of the seal facing the rear tail jaws.
- Complete assembly in reverse order of dismantling.

TAIL JAW ON/OFF VALVE

- The unit is designed so that minimum of servicing is required during the life of the tool.
- If it is necessary to dismantle valve, proceed as follows:
- Remove Switch Block **55** as described in section "Hydraulic Piston".
- Using a screwdriver*, carefully remove the Chrome Star-lock Washer **22** from Air Tail Jaw Spool **49** and discard washer.
- Extract Air Tail Jaw Spool **49** from Switch Block **55**.
- Taking care not to damage the Air Tail Jaw Spool **49**, remove the 'O' Rings **11**.
- Clean spool and refit new 'O' Rings **11** using assembly bullet* and insert into Switch Block **55**, noting its orientation.
- Fit New Chrome Star-lock Washer **22** by clamping in vice using a soft jaw vice to prevent damage. DO NOT USE UNDUE FORCE.
- Complete assembly in reverse order of dismantling.

HANDLE & END CAP

- Clean and inspect mouldings for cracks or other damage.

CURSOR

- Clean and oil Mechanical Cursor **36** occasionally with a little light oil.

IMPORTANT

Check the tool against daily and weekly servicing.
Priming is ALWAYS necessary after the tool has been dismantled and prior to operating.

* Refers to items included in the service kits 07900-05300 & 71210-99990. For complete list see page 23.
Item numbers in **bold** refer to the general assemblies and parts lists on pages 26-27.

General Assembly of 07537-00200 Tool

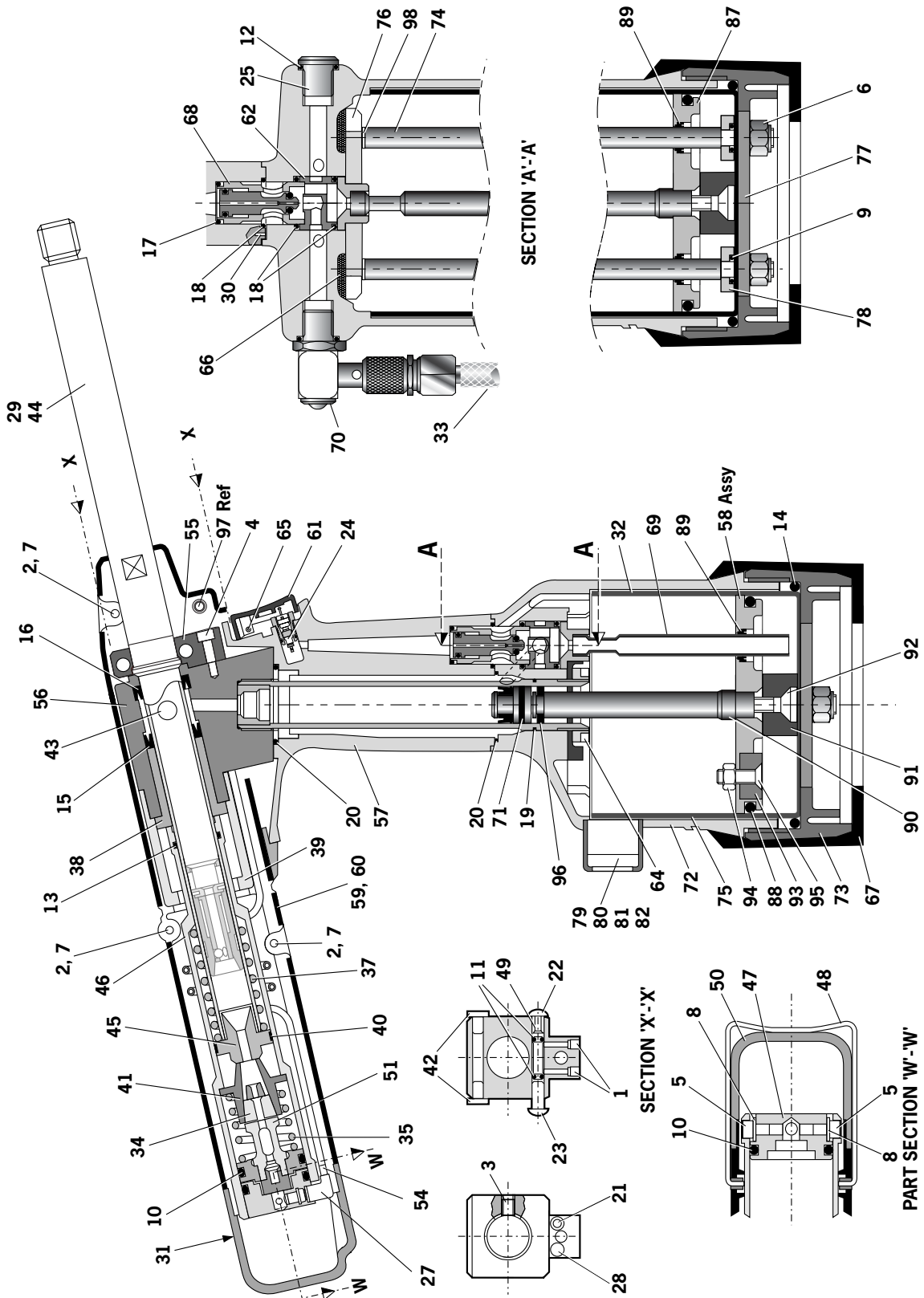

Parts List for 07537-00200 Tool

07537-00200 PARTS LIST

ITEM	PART N°	DESCRIPTION	QTY	SPARES	ITEM	PART N°	DESCRIPTION	QTY	SPARES	ITEM	PART N°	DESCRIPTION	QTY	SPARES
01	07001-00223	M4 x 5 LONG SKT HD GRUB SCREW	2	-	41	07530-00208	JAW HOUSING	1	-	81	71221-20103	MOULD RETAINING NUT	2	-
02	07001-00401	M4 x 10 LONG SKT HD CAP SCREW	3	-	42	07530-00310	BLEANKING PLUG	2	-	82	71221-20105	MODIFIED COUNTER	1	-
03	07001-00404	M5 x 6 LONG SKT HD SET SCREW	1	-	43	07530-00500	BLEANK PLUG Assembly (Items 83 to 86)	1	-	83	07003-00142	BONDED SEAL	1	1
04	07001-00445	M4 X 15 LONG SKT HD CAP SCREW	1	-	44	07530-02201	BARREL	1	-	84	07003-00194	BONDED SEAL	1	1
05	07001-00504	M4 X 6 LONG SKT HD CAP SCREW	2	2	45	07530-02205	BARREL PLUG	1	-	85	07001-00442	SCREW	1	-
06	07002-00108	M6 NYLON NUT	2	-	46	07530-02207	TAIL JAW CYLINDER	1	-	86	07530-00501	PLUG	1	-
07	07002-00134	M4 HEX NUT	3	-	47	07530-02213	REAR PLUG	1	-	87	71211-03201	PISTON	1	-
08	07002-00153	M4 WASHER (PLASTIC)	2	-	48	07530-02220	CLIP	1	-	88	07003-00280	'O' RING	1	1
09	07003-00027	'O' RING	2	-	49	07530-02302	AIR TAIL JAW SPOOL	1	-	89	07003-00274	SEAL/WIPER	3	-
10	07003-00113	'O' RING	2	2	50	07530-02603	END CAP	1	-	90	71211-03202	INTENSIFIER ROD	1	-
11	07003-00121	'O' RING	2	2	51	07530-02800	TAIL JAW PISTON ASSEMBLY	1	-	91	07537-00501	SPACER	1	-
12	07003-00127	'O' RING	1	-	52	07537-00201	AIR TAIL JAW ASSEMBLY	2	-	92	07001-00411	M6x25 C'SK HEAD SCREW	1	-
13	07003-00167	'O' RING	1	1	53	07537-00202	LABEL (NOT SHOWN)	1	-	93	07007-01993	CENTRE POLE MAGNET	1	-
14	07003-00418	'O' RING	2	-	54	07537-00203	AIR TAIL JAW CONCERTINA TUBE	1	-	94	07002-00098	M5 NYLON NUT	1	-
15	07003-00236	LIP SEAL (DYNAMIC)	1	1	55	07537-00204	SWITCH BLOCK	1	-	95	71221-20104	M5x19 C'SK SCREW	1	-
16	07003-00237	LIP SEAL (STATIC)	2	-	56	07537-00300	HEAD ASSEMBLY	1	-	96	71210-03205	GUIDE RING	1	-
17	07003-00271	'O' RING	1	-	57	07537-00400	HANDLE ASSEMBLY	1	-	97	07001-00442	M5x6 LONG SKT HD BUTTON SCREW	1	-
18	07003-00281	'O' RING	3	-	58	07537-00500	PNEUMATIC PISTON Assembly (87 to 96)	1	-	98	07002-00163	WASHER	2	-
19	07003-00287	'O' RING	1	-	59	07537-00600	07537 BODY MOULDING ASSEMBLY - RH	1	-					
20	07003-00288	'O' RING	2	-	60	07537-00700	07537 BODY MOULDING ASSEMBLY - LH	1	-					
21	07003-00383	'O' RING - (I/D 3.00 Sec 1.00)	2	-	61	71210-02008	TRIGGER	1	-					
22	07004-00058	1/8" STARLOCK WASHER CHROME	1	-	62	71210-02009	VALVE SEAT	1	-					
23	07004-00059	1/8" STARLOCK WASHER BLACK	1	-	63									
24	07005-00088	TRIGGER VALVE	1	-	64	71210-02014	CLAMP NUT	1	-					
25	07005-01274	1/8" BSP PLUG	1	-	65	71210-02024	TRIGGER PIN	1	-					
26					66	71210-02031	SILENCER	2	-					
27	07005-01972	L TYPE THREADED NIPPLE	1	-	67	71210-02055	RUBBER BOOT	1	-					
28	07005-10057	NONRETURN VALVE	1	-	68	71210-03400	VALVE SPOOL ASSEMBLY	1	-					
29	07007-00017	DUST CAP	1	-	69	07537-00810	TRANSFER TUBE ASSEMBLY	1	-					
30	07007-00224	DIA 3 x 10 LONG SPIRAL PIN	2	-	70	71210-03700	ON / OFF VALVE ASSEMBLY	1	-					
31	07007-01503	BOOK SYMBOL LABEL (NOT SHOWN)	1	-	71	71210-03800	INTENSIFIER SEAL ASSEMBLY	1	-					
32	07007-01504	CE MARK LABEL (NOT SHOWN)	1	-	72	71211-02001	BODY MACHINED	1	-					
33	07008-00010	6" FLEXIBLE HOSE	1	-	73	71211-02002	BASE COVER MACHINED	1	-					
34	07151-00403	JAWS	2	2	74	71211-02004	TIE RODS	2	-					
35	07154-00404	SPRING	1	-	75	71211-02008	CYLINDER LINER	1	-					
36					76	71213-02010	TOP PLATE ASSEMBLY	1	-					
37	07490-03002	BARREL RETURN SPRING	1	-	77	71221-02005	BASE PLATE	1	-					
38	07530-00203	PISTON	1	-	78	71221-02006	SEALING WASHER	2	-					
39	07530-00204	STROKE LIMITER	1	-	79	71221-20101	COUNTER MOULDING	1	-					
40	07530-00206	RUBBING STRIP	1	1	80	71221-20102	SPECIAL M4 SCREW	2	-					

Priming

Priming is ALWAYS necessary after the tool has been dismantled and prior to operating. It may also be necessary to restore the full stroke after considerable use, when the stroke may be reduced and fasteners are not fully placed by one operation of the trigger.

Oil Details

The recommended oil for priming is Hyspin® VG 32 available in 0.5l (part number 07992-00002) or one gallon containers (part number 07992-00006). Please find specific table and safety data below.

Hyspin® VG 32 and AWS Oil Safety Data

First Aid

SKIN:

Wash thoroughly with soap and water as soon as possible. Casual contact requires no immediate attention. Short term contact requires no immediate attention.

INGESTION:

Seek medical attention immediately. DO NOT induce vomiting.

EYES:

Irrigate immediately with water for several minutes. Although NOT a primary irritant, minor irritation may occur following contact.

Fire

Flash point: 232°C. Not classified as flammable.

Suitable extinguishing media: CO₂, dry powder, foam or water fog. DO NOT use water jets.

Environment

WASTE DISPOSAL: Through authorised contractor to a licensed site. May be incinerated. Used product may be sent for reclamation.

SPILLAGE: Prevent entry into drains, sewers and water courses. Soak up with absorbent material.

Handling

Wear eye protection, impervious gloves (e.g. of PVC) and a plastic apron. Use in well ventilated area.

Storage

No special precautions.

Priming Pump

To enable you to follow the priming procedure opposite, you will need to obtain a priming pump 07900-00700:

Priming

Priming Procedure

I M P O R T A N T

DISCONNECT THE TOOL FROM THE AIR SUPPLY OR SWITCH OFF AT VALVE 70.
All operations should be carried out on a clean bench, with clean hands in a clean area.
Ensure that the new oil is perfectly clean and free from air bubbles.
Care MUST be taken at all times, to ensure that no foreign matter enters the tool, or serious damage may result.

- Remove Bleed Screw **85** and Bonded Seal **84**.
- Connect air supply to tool and switch ON/OFF Valve **70** to 'ON" position.
- Invert tool over suitable container and actuate trigger. Waste oil will be ejected through the bleed screw hole.

CARE SHALL BE TAKEN TO ENSURE THAT THE BLEED HOLE IS NOT DIRECTED TOWARDS THE OPERATOR OR OTHER PERSONNEL.

- Disconnect air supply to tool or switch ON/OFF Valve **70** to 'OFF" position.
- Fill the priming pump with oil.
- Screw priming pump 07900-00700 into the bleed screw hole with Bonded Seal **84** in place.
- Actuate the priming pump by pressing down and releasing several times until resistance is felt.
- Remove the priming pump.
- Replace Bleed Screw **85** and Bonded Seal **84**.
- Connect air supply to tool and switch ON/OFF valve **70** to 'ON" position.
- Check that the stroke of the tool meets the minimum specification of 30 millimetres. To check the stroke, measure the distance between the rear of the tail jaw cylinder and body mouldings, BEFORE pressing the trigger and when the trigger is fully actuated. The stroke is the difference between the two measurements. If it does not meet the minimum specification, repeat the priming procedure.

Item numbers in **bold** refer to the general assembly drawing and parts list on pages 26-27.

Fault Diagnosis

Symptom	Possible Cause	Remedy	Page Ref
Tool will not place fastener	Low air pressure.	Increase air pressure	
	Lack of lubrication.	Lubricate tool at air inlet point	
	High broach load.	Check fastener grip and application hole size	
	Check for correct size mandrel.		
	Worn or broken tail jaws.	New tail jaws	
	Tail jaws switched off.	Switch on tail jaws	
	Air in hydraulic system.	See 'Priming Procedure'	29
'Mandrel Slip' - jaws will not grip mandrel	Worn or dirty tail jaws.	Clean or renew as necessary	
	' Insufficient air pressure/volume.	Increase air pressure/volume	
	' Tail jaw switch inoperable.	Replace switch	
	' Air leaks to tail jaws.	Renew 'O' Rings 10 on Piston Assembly 51	
	Mandrel broken and not reaching tail jaws.	Replace mandrel	
	Defective non-return valve.	Replace non-return valve	
Jaws will not release mandrel	Dirty tail jaws or jaw housing.	Clean and lubricate	
	Faulty tail jaw switch.	Replace 'O' rings	
Fasteners will not feed through nose jaws	Tail jaws not switched on.	Switch on tail jaws	
	Worn tail jaws.	Renew tail jaws	
	Cursor orientation incorrect.	Refit, ensuring correct orientation	
	Incorrect nose jaws.	Fit correct nose jaws	
	Mandrel follower spring not fitted.	Fit correct mandrel follower spring	
	Incorrect gap between fastener head and nose jaws when loaded.	Set gap to 1.5mm - 3mm (1/16" - 1/8") See 'Loading the Tool'	10
	Cursor sticking.	Clean and oil cursor	
	Weak outer spring around cursor.	Renew cursor	
Incorrect mandrel follower spring fitted.	Fit correct mandrel follower spring		
Excessive tail jaw wear	High broach load.	Check application hole size and thickness and fastener grip capability	
Feeding more than one fastener at a time	Mandrel slip.	Check as for 'Mandrel Slip', stage 2	
	Incorrect gap between fastener head and nose jaws when loaded	Set gap to 1.5mm - 3mm (1/16" - 1/8") See 'Loading the Tool'	10

Other symptoms or failures should be reported to your local Avdel authorised distributor or repair centre.

Declaration of Conformity

We, Avdel UK Limited; Watchmead Industrial Estate, Welwyn Garden City, Hertfordshire, AL7 1LY
declare under our sole responsibility that the product:

Model 07537

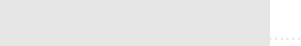
Serial No. 

to which this declaration relates is in conformity with the following standards:

EN ISO 12100 - parts 1 & 2

BS EN ISO 8662 - part 6

BS EN ISO 3744

ISO EN 792 - part 13-2000

BS EN ISO 11202

BS EN 982

BS EN 983

following the provisions of the Machine Directive 98/37/EC



A. Seewraj - Product Engineering Manager Automation Tools

Date of issue



**This box contains a power tool which is in
conformity with Machines Directive
98/37/EC. The 'Declaration of Conformity' is
contained within.**



An Acument™ Global Technologies Company

AUSTRALIA

Acument Australia Pty Ltd.

891 Wellington Road
Rowville, Victoria 3178
Tel: +61 3 9765 6400
Fax: +61 3 9765 6445
Email: info@acument.com.au

CANADA

**Avdel Canada, a Division of Acument
Canada Limited.**

87 Disco Road
Rexdale
Ontario M9W 1M3
Tel: +1 416 679 0622
Fax: +1 416 679 0678
Email: infoAvdel-Canada@acument.com

CHINA

Acument China Ltd.

RM 1708, 17/F., Nanyang Plaza,
57 Hung To Rd., Kwun Tong
Hong Kong
Tel: +852 2950 0631
Fax: +852 2950 0022
Email: infochina@acument.com

FRANCE

Avdel France S.A.S.

33 bis, rue des Ardennes
BP4
75921 Paris Cedex 19
Tel: +33 (0) 1 4040 8000
Fax: +33 (0) 1 4208 2450
Email: AvdelFrance@acument.com

GERMANY

Avdel Deutschland GmbH

Klusriede 24
30851 Langenhagen
Tel: +49 (0) 511 7288 0
Fax: +49 (0) 511 7288 133
Email: AvdelDeutschland@acument.com

ITALY

Avdel Italia S.r.l.

Viale Lombardia 51/53
20047 Brugherio (MI)
Tel: +39 039 289911
Fax: +39 039 2873079
Email: vendite@acument.com

JAPAN

Acument Japan Kabushiki Kaisha

Center Minami SKY,
3-1 Chigasaki-Chuo, Tsuzuki-ku,
Yokohama-city, Kanagawa Prefecture
Japan 224-0032
Tel: +81 45 947 1200
Fax: +81 45 947 1205
Email: info@acument.co.jp

SINGAPORE

Acument Asia Pacific (Pte) Ltd.

#05-03/06 Techlink
31 Kaki Bukit Road 3
Singapore, 417818
Tel: +65 6840 7431
Fax: +65 6840 7409
Email: Tlim@acument.com

SOUTH KOREA

Acument Korea Ltd.

212-4, Suyang-Ri,
Silchon-Eup, Kwangju-City,
Kyunggi-Do, Korea, 464-874
Tel: +82 31 798 6340
Fax: +82 31 798 6342
Email: info@acumentkorea.com

SPAIN

Avdel Spain S.A.

C/ Puerto de la Morcuera, 14
Poligono Industrial Prado Overa
Ctra. de Toledo, km 7,8
28919 Leganés (Madrid)
Tel: +34 (0) 91 3416767
Fax: +34 (0) 91 3416740
Email: ventas@acument.com

UNITED KINGDOM

Avdel UK Limited

Pacific House
2 Swiftfields
Watchmead Industrial Estate
Welwyn Garden City
Hertfordshire
AL7 1LY
Tel: +44 (0) 1707 292000
Fax: +44 (0) 1707 292199
Email: enquiries@acument.com

USA

Avdel USA LLC

614 NC Highway 200 South
Stanfield,
North Carolina 28163
Tel: +1 704 888-7100
Fax: +1 704 888-0258
Email: infoAvdel-USA@acument.com

© Avdel UK Limited 2007

Manual No.	Issue	Change Note No.	Date
07900-00845	AA	05/012	MAR 05
	AB	05/260	JUNE 05
	AC	06/160	AUG 06
	B	07/044	FEB 07
	B2	07/103	MAR 07
	B3	07/172	OCT 07

Avdel®, Avdel® SR, Avlug®, Avsert®, Avtronic®, Briv®, Chobert®, Grovit®, Rivscrew® are trademarks of Avdel UK Limited.

www.avdel-global.com